



SDS73H SERIES

SMD Shielded Power Inductors



RoHS Compliant

PART NUMBERING SYSTEM

SDS	73H	—	100M	—	LF
TYPE	DIMENSIONS		INDUCTANCE		LEAD FREE

SHAPES AND DIMENSIONS

UNIT : mm

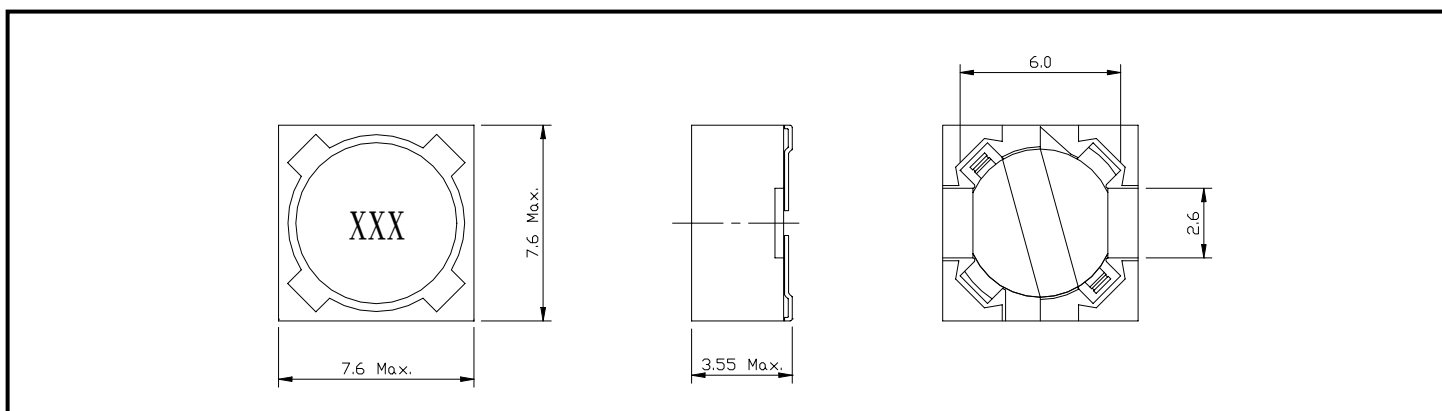

PACKAGING SPECIFICATION

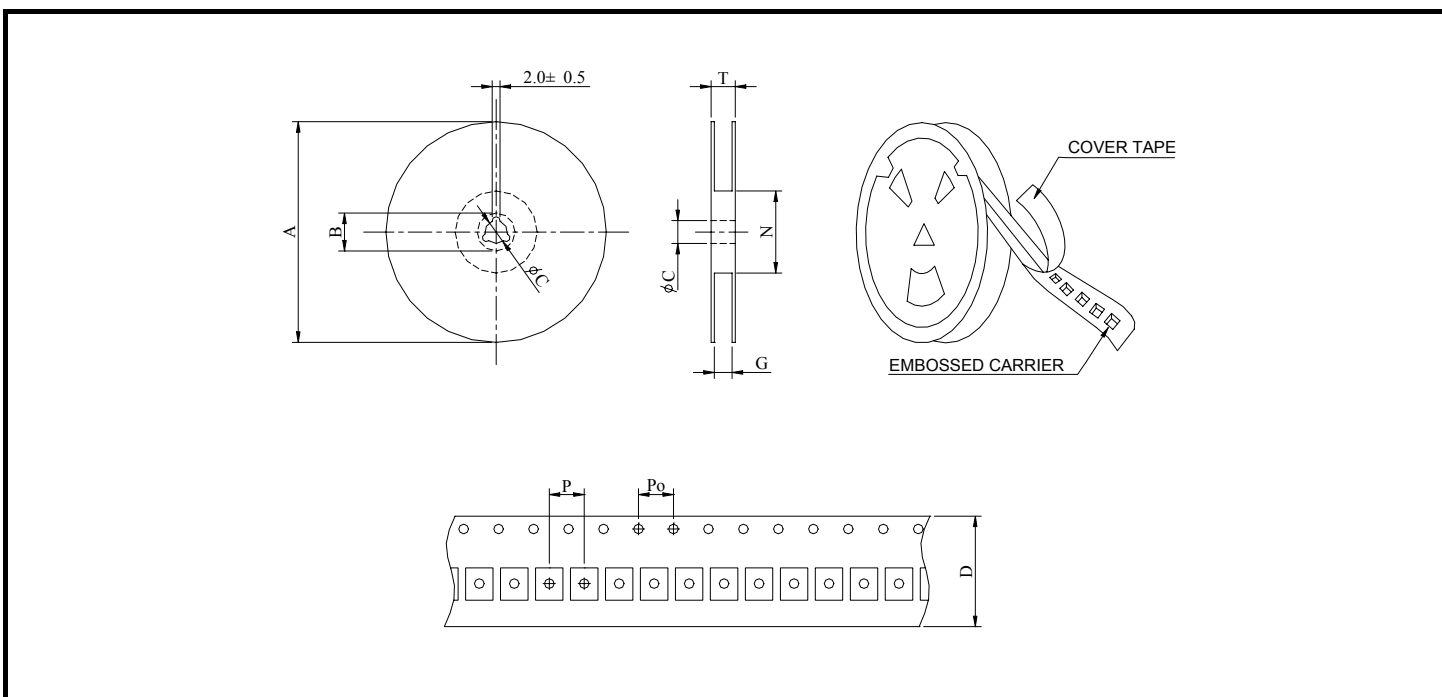

SERIES	STAYLE	Q' TY (PCS)	DIMENSIONS (m/m)								
			A	B±0.8	C±0.5	D	G ⁺⁰	N ⁰	P	Po	T
SDS73H	13-16	1000	330	21	13	16	18	50	8	4	22.4



SDS73H SERIES

SMD Shielded Power Inductors



RoHS Compliant

SPECIFICATION TABLE

PART NUMBER	INDUCTANCE (μ H)	DCR (Ω) (Max.)	IDC (A) (Max.)	TEST FREQ. (f)
SDS73H-R33M-LF	0.33 \pm 20%	0.0095	14.4	100KHz
SDS73H-1R0M-LF	1.00 \pm 20%	0.0133	7.97	100KHz
SDS73H-1R5M-LF	1.50 \pm 20%	0.0169	6.52	100KHz
SDS73H-2R2M-LF	2.20 \pm 20%	0.0215	5.52	100KHz
SDS73H-3R3M-LF	3.30 \pm 20%	0.0337	4.22	100KHz
SDS73H-4R7M-LF	4.70 \pm 20%	0.0386	3.78	100KHz
SDS73H-6R8M-LF	6.80 \pm 20%	0.0566	3.12	100KHz
SDS73H-8R2M-LF	8.20 \pm 20%	0.0770	2.66	100KHz
SDS73H-100M-LF	10 \pm 20%	0.0853	2.47	100KHz
SDS73H-150M-LF	15 \pm 20%	0.1100	2.05	100KHz
SDS73H-220M-LF	22 \pm 20%	0.1391	1.67	100KHz
SDS73H-330M-LF	33 \pm 20%	0.2158	1.35	100KHz
SDS73H-470M-LF	47 \pm 20%	0.3133	1.14	100KHz
SDS73H-680M-LF	68 \pm 20%	0.4654	0.96	100KHz
SDS73H-820M-LF	82 \pm 20%	0.4992	0.89	100KHz
SDS73H-101M-LF	100 \pm 20%	0.6851	0.79	100KHz
SDS73H-151M-LF	150 \pm 20%	1.1063	0.65	100KHz
SDS73H-221M-LF	220 \pm 20%	1.3650	0.53	100KHz
SDS73H-331M-LF	330 \pm 20%	2.0670	0.44	100KHz
SDS73H-471M-LF	470 \pm 20%	3.0680	0.37	100KHz
SDS73H-681M-LF	680 \pm 20%	4.5110	0.31	100KHz
SDS73H-821M-LF	820 \pm 20%	5.1090	0.28	100KHz
SDS73H-102M-LF	1000 \pm 20%	5.6420	0.25	100KHz

- DC current at which the inductance drops 30% (typ) from its value without current.
- Operating temperature range -40°C to +85°C.
- Electrical specifications at 20°C .