



# Coilmaster



RoHS Compliant

## SPECIFICATION APPROVAL

CUSTOMER : SIRICOM

PRODUCT : SDC5D28-4R7M-LF

Pb-free

CODE NO. : C00952046

CUS. CODE :

SPEC.NO. : C-0952-046(02)

DATE : 1-Nov-06

CUSTOMER APPROVAL

**Coilmaster Electronics Co., Ltd.**

9F-3,NO.398 HUAN BEI ROAD, CHUNG-LI CITY

TAOYUAN HSIEN, TAIWAN, R.O.C.

TEL : (886)34228279 FAX : (886)34228734

PREPARED BY	APPROVED BY	AUTHORIZED BY
JEAN	TONY	MASCOT

PRODUCT	SDC5D28-4R7M-LF	<b>COIL SPECIFICATION</b>	DATE	2006/11/1
SPEC.NO.	C-0952-046(02)		CODE NO.	C00952046

**EXTERNAL DIMENSIONS :**

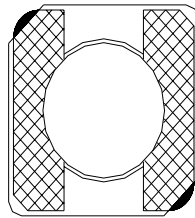
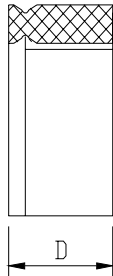
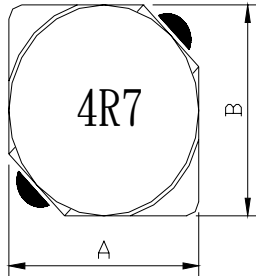

A : 5.7±0.3 m/m  
 B : 5.7±0.3 m/m  
 D : 3.0 Max. m/m

**ELECTRICAL CHARACTERISTIC :**

L(μH) : 4.7±20% 1MHz 0.25V  
 DCR(mΩ) : 42 Max.  
 IDC(A) : 2.2 Max. ( L2.2A MAX ≥ 0Ax65% )  
 INDUCTANCE DROP :35% MAX @ IDC 2.2 A  
 Operating Temperature Range -40°C ~ +85°C

**SCHEMATIC DRAWING :**

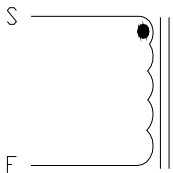

φ Ts(Ref.)

"●" START FOR STAND

**PCB PATTERN :**

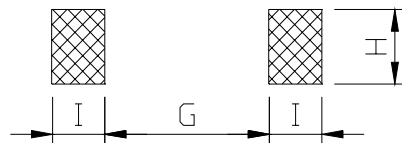

G: 2 m/m  
 H: 6.3 m/m  
 I: 2.15 m/m

**MATERIAL LIST :**

NO	ITEM	MATERIAL	SUPPLIER OF THE MATERIAL
1	CORE		
2	BASE		
3	WIRE		
4	EPOXY		

PRODUCT	SDC5D28-4R7M-LF	<b>COIL SPECIFICATION</b>	DATE	2006/11/1
SPEC.NO.	C-0952-046(02)		CODE NO.	C00952046

**TEST DATA**

ELECTRICAL CHARACTERISTICS								
MEAS. ITEM	L(μH)	DCR(mΩ)	IDC(A)					
TEST FREQ.	1MHz 0.25V	Max.	Max.					
YOUR			L(2.2A)					
SPEC.	4.7±20%	42	≥ 0Ax65%					
1								
2								
3								
4								
5								
6								
7								
8								
9								
10								
X	#DIV/0!	#DIV/0!						
R	0.00	0.000						

DIMENSION								
MEAS. ITEM	A	B	C	D				
TEST FREQ.	m/m	m/m	m/m	m/m				
YOUR								
SPEC.	5.7±0.3	5.7±0.3		3.0 Max.				
1								
2								
3								
4								
5								
6								
7								
8								
9								
10								
X	#DIV/0!	#DIV/0!		#DIV/0!				
R	0.00	0.000		0.00				

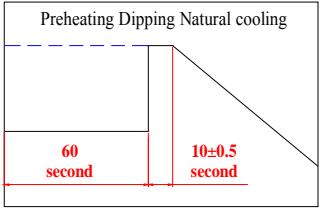
PRODUCT	SDC5D28-4R7M-LF	COIL SPECIFICATION	DATE	2006/11/1
SPEC.NO.	C-0952-046(02)		CODE NO.	C00952046
TEST ITEMS	SPECIFICATIONS	TEST CONDITIONS / TEST METHODS		
<b><u>ELECTRICAL PERFORMANCE TEST</u></b>				
L	REFER TO STANDARD ELECTRICAL CHARACTERISTIC LIST.	CH-1061 OR EQUIV.		
DCR		CH-502A OR EQUIV		
RATED CURRENT		APPLIED THE CURRENT TO COILS THE INDUCTANCE CHANGE SHOULD BE LESS THAN 35% TO INITIAL VALUE AND TEMPERATURE RISE SHOULD NOT BE MORE THAN 40°C..		
TEMPERATURE RISE TEST		40°C MAX ( $\Delta t$ )	1. APPLIED THE ALLOWED DC CURRENT FOR 4 HOURS. 2. TEMPERATURE MEASURE BY DIGITAL SURFACE THERMOMETER.	
OVER LOAD TEST	NO EVIDENCE OF ELECTRICAL DAMAGE	APPLIED 1.5 TIMES OF RATED ALLOWED DC CURRENT TO INDUCTORS FOR A PERIOD OF 5 MINUTES.		
<b><u>MECHANICAL PERFORMANCE TEST</u></b>				
SOLDER HEAT RESISTANCE	1. INDUCTORS SHOULD HAVE NO EVIDENCE OF ELECTRICAL AND MECHANICAL DAMAGE 2. INDUCTANCE SHOULD NOT CHANGE MORE THAN $\pm 10\%$ 3. SOLDER MATERIAL WILL BE LEAD FREE.	PREHEAT: 150°C 60SECS		
		SOLDER TEMPERATURE: 255 $\pm$ 5°C		
		FLUX: ROXIN.. DIP TIME: 10 $\pm$ 0.5SECS.		
VIBRATION TEST (LOW FREQUENCY)				
SHOCK TEST		1.AMPLITUDE: 1.5 mm 2.FREQUENCY: 10-55-10HZ / 1 MIN 3.DIRECTION: X, Y, Z 4.DURATION: 2 HRS/X, Y, Z INDUCTORS SHOULD BE DROPPED 10 TIMES FROM A HEIGHT OF 1m ONTO 3cm WOODEN BOARD.		

**COILMASTER ELECTRONICS CO., LTD.**

PRODUCT	SDC5D28-4R7M-LF	COIL SPECIFICATION	DATE	2006/11/1
SPEC.NO.	C-0952-046(02)		CODE NO.	C00952046
TEST ITEMS	SPECIFICATIONS	TEST CONDITIONS / TEST METHODS		
<b><u>MECHANICAL PERFORMANCE TEST</u></b>				
SOLDERABILITY TEST	MORE THAN 90% OF TERMINAL ELECTRODE SHOULD BE COVERED WITH SOLDER.	AFTER FLUXING, INDUCTOR SHALL BE DIPPED IN A MELTED SOLDER BATH AT 255±5°C FOR 5 SECONDS		
COMPONENT ADHESION ( PUSH TEST )	1.5Kg Min	THE DEVICE SHOULD BE REFLOW SOLDERED ( 255±5°C FOR 10 SECONDS ) TO A TINNED COPPER SUBSTRATE. A DYNAMETER FORCE GAUGE SHOULD BE APPLIED TO THE SIDE OF THE COMPONENT. THE DEVICE MUST WITH- STAND A MINIMUM FORCE OF 1.5Kg WITHOUT AILURE OF THE TERMINATION . ATTACHED TO COMPONENT.		
COMPONENT ADHESION ( PULL TEST )	1.5Kg Min	1.INSERT 10cm WIRE INTO THE REMAINING OPEN EYE BEND THE ENDS OF EVEN WIRE LENGTHS UPWARD AND WIND TOGETHER 2. TERMINAL SHALL NOT BEREMARKABLY DAMAGED		
FLEXTURE STRENGTH	THE FORCES APPLIED SHOULD NOT DAMAGE THE DIELECTRIC.	SOLDER A CHIP ON A TEST SUBSTRATE, BEND THE SUBSTRATE BY 2mm AND RETURN.		
RESISTANCE TO SOLVENT TEST	THERE SHOULD BE NO CASEDEFORMATION, CHANGE IN APPEARANCE OR BITERATION OF MARKING	INDUCTERS SHALL WITHSTAND 6 MINTES OF ALCOHOL		

PRODUCT	SDC5D28-4R7M-LF	COIL SPECIFICATION	DATE	2006/11/1
SPEC.NO.	C-0952-046(02)		CODE NO.	C00952046
TEST ITEMS	SPECIFICATIONS	TEST CONDITIONS / TEST METHODS		
<b><u>CLIMATIC TEST</u></b>				
TEMPERATURE CHARACTERISTIC	1.APEARANCE:NO DAMAGE 2.INDUCTANCE:WITHIN±10% OF INITIAL VALUE.	- 40°C ~ +85°C		
HUMIDITY TEST		60°C±2°C / 96±2 HOURS		
LOW TEMPERATURE STORAGE		1.TEMPERATURE:- 25°C±2°C 2.TIME: 96±2 HOURS		
THERMAL SHOCK TEST		1.-25±5°C FOR 30 MINUTES. +80±5°C FOR 30 MINUTES. 2.TOTAL: 10 CYCLES		
HIGH TEMPERATURE STORAGE		1.APPLIED CURRENT: MAX RATED CURRENT 2.TEMPERATURE:80°C±2°C		
NOTE : INDUCTORS ARE TO BE TESTED AFTER 2 HOUR AT ROOM TEMPERATURE.				
<b><u>LIFE TEST</u></b>				
HIGH TEMPERATURE LOAD LIFE TEST	INDUCTORS SHOULD BE NO EVIDENCE OF SHORT OR OPEN CIRCUIT	1. TEMPERATURE: 80±2°C 2. TIME: 500±12 HOURS 3. LOAD: ALLOWED DC CURREN		
HUMIDITY LOAD LIFE TEST		1. TEMPERATURE: 60±2°C 2. R.H.: 90-95% 3. TIME: 500±12 HOURS 4. LOAD: ALLOWED DC CURREN		

**COILMASTER ELECTRONICS CO., LTD.**

PRODUCT	SDC5D28-4R7M-LF	<b>COIL SPECIFICATION</b>	DATE	2006/11/1
SPEC.NO.	C-0952-046(02)		CODE NO.	C00952046

**RECOMMENDED SOLDERING CONDITIONS :**

CLASSIFICATION REFLOW PROFILES

Profile Feature	Sn-Pb Eutectic Assembly		Pb-Free Assembly	
	Large Body	Small Body	Large Body	Small Body
Average ramp-up rate ( $T_L$ to $T_P$ )	3°C/second max.		3°C/second max.	
Preheat				
-Temperature Min ( $T_{smin}$ )	100°C		150°C	
-Temperature Min ( $T_{smax}$ )	150°C		200°C	
-Time (min to max) (ts)	60-120 seconds		60-180 seconds	
$T_{smax}$ to $T_L$				
-Ramp-up Rate			3°C/second max.	
Time maintained above:				
-Temperature ( $T_L$ )	183°C		217°C	
-Time ( $t_L$ )	60-150 seconds		60-150 seconds	
Peak Temperature ( $T_P$ )	225 +0/-5°C	240 +0/-5°C	245 +0/-5°C	255 +5/-5°C
Time within 5°C of actual Peak Temperature ( $t_p$ )	10-30 seconds	10-30 seconds	10-30 seconds	20-40 seconds
Ramp-down Rate	6°C/second max.		6°C/second max.	
Time 25°C to Peak Temperature	6 minutes max.		8 minutes max.	

Note : All temperatures refer to topside of the package. Measured on the package body surface.

REFLOW SOLDERINGS

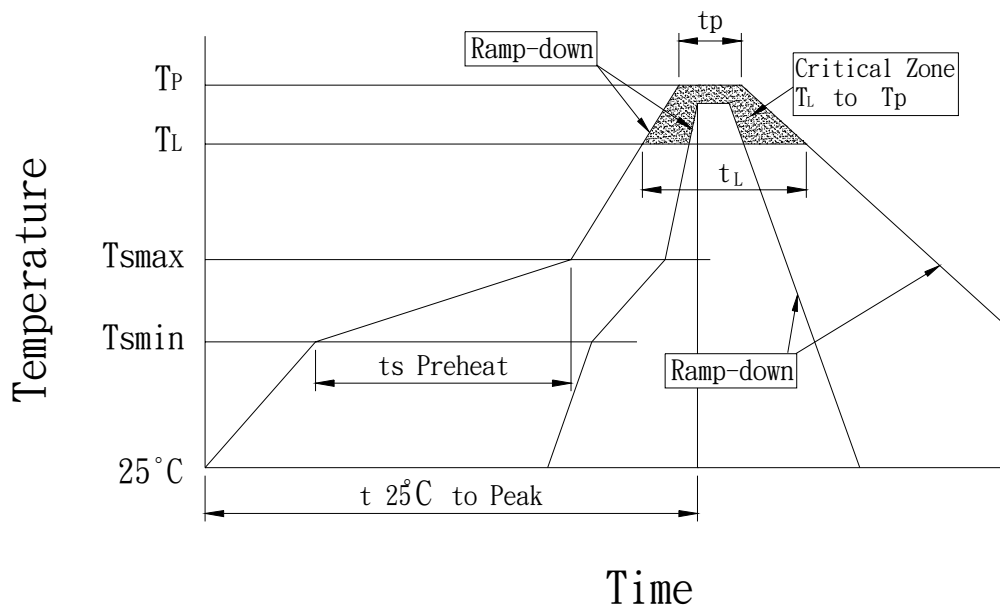

PRODUCT	SDC5D28-4R7M-LF	<b>COIL SPECIFICATION</b>	DATE	2006/11/1
SPEC.NO.	C-0952-046(02)		CODE NO.	C00952046

**PACKAGE :**

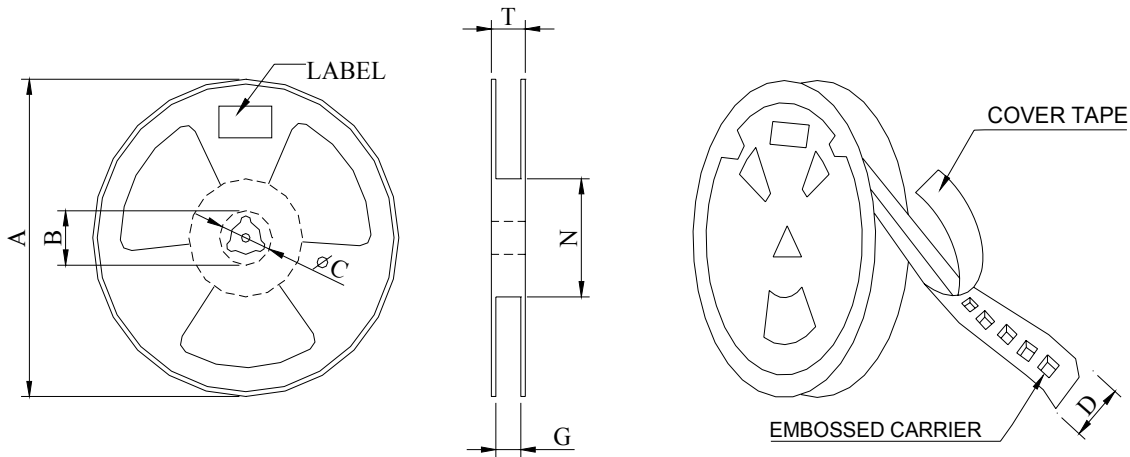

\*CARRIER TAPE WIDTH : D

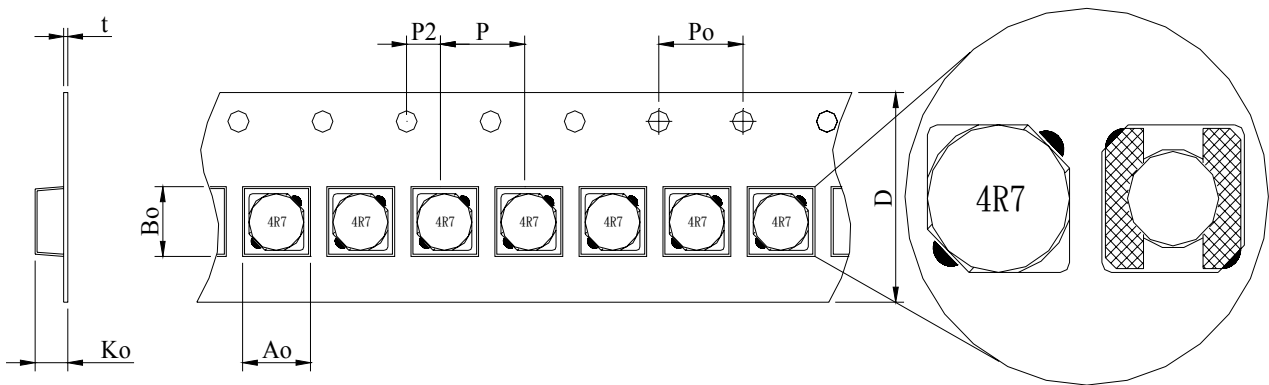

STAYLE	DIMENSIONS (m/m)														
	Q'TY (PCS)	A	B	C	D	G	N	T	Ao	Bo	Ko	t	P	Po	P2
—	2000	330	—	13.5 ±0.5	12.0 ±0.3	12.0 ±0.5	75.0 ±2.0	—	6.20 ±0.2	6.20 ±0.2	3.2 ±0.1	0.4 ± 0.1	8.0 ±0.1	4.0 ±0.1	2.0 ±0.1



PRODUCT	SDC5D28-4R7M-LF	<b>COIL SPECIFICATION</b>	DATE	2006/11/1
SPEC.NO.	C-0952-046(02)		CODE NO.	C00952046

TABLE :

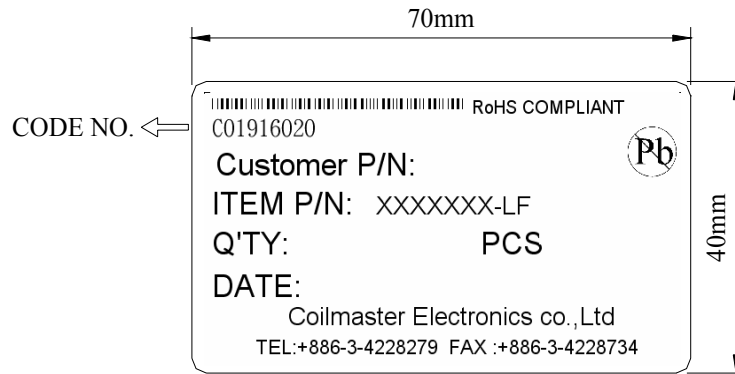

INNER BOX LABEL

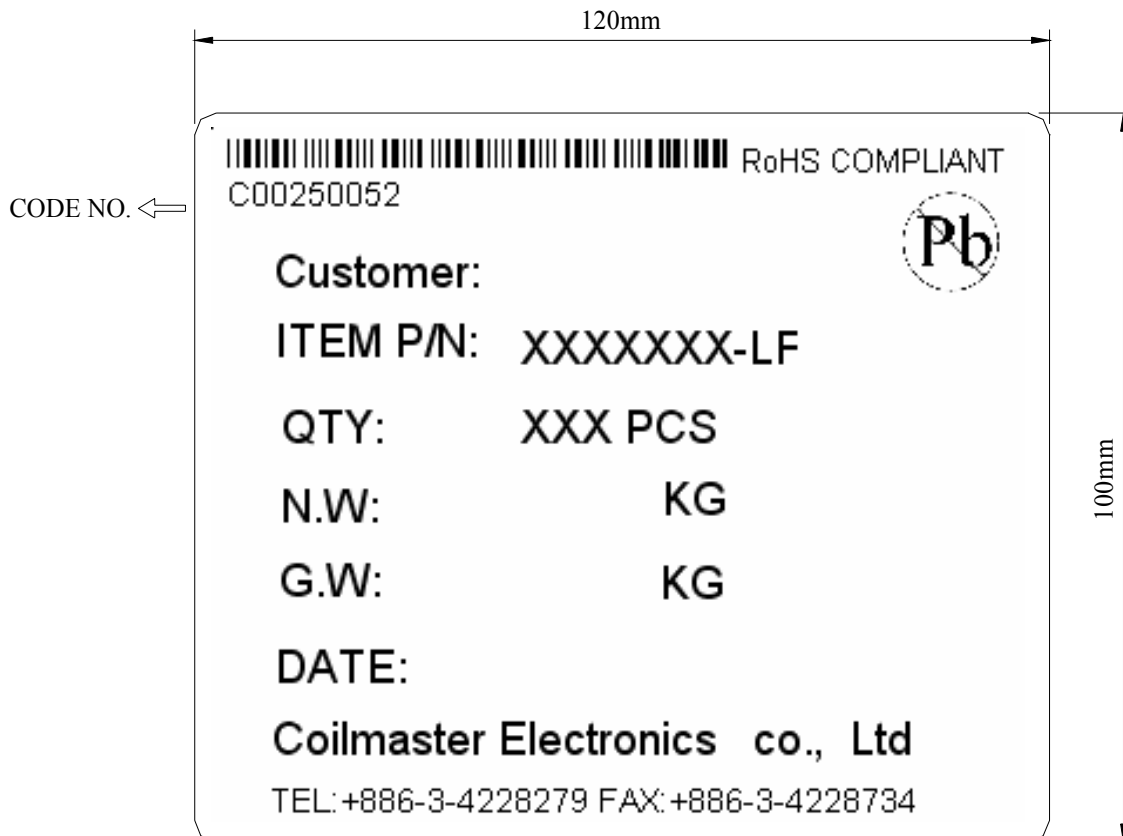

OUT BOX LABEL

**COILMASTER ELECTRONICS CO., LTD.**