

InPower Semiconductor

January 2007





MOSFET Product Line (1)

Part Number	Voltage (V)	Current (A)	Rdson (Ohm)	Package	Application	Mass Production
FTP8N06	55	110	0.008	TO-220	DC Motor, UPS	Q1/07
FTP18N06	60	59	0.018	TO-220	DC Motor, UPS	Now
FTP16N06	60	60	0.016	TO-220	DC Motor, UPS	Q1/07
FTP12N06	60	84	0.012	TO-220	DC Motor, UPS	Q1/07
FTP11N08	75	80	0.011	TO-220	DC Motor, UPS	Q1/07
FTD9N20	200	8.6	0.4	TO-252	Telcom, Datacom	Now
FTP9N20	200	8.6	0.4	TO-220	CRT, Inverter	Now
FTB18N20	200	18	0.18	TO-263	Telcom, Datacom	Now
FTP18N20	200	18	0.18	TO-220	CRT, Inverter	Now
FTP8N25	250	8	0.435	TO-220	CRT, Inverter	Now
FTP8NS25	250	8	0.435	TO-220	CRT, Inverter	Now
FTP6N40	400	5.5	1	TO-220	Ballast, Inverter	Now
FTP10N40	400	10	0.54	TO-220	Ballast, Inverter	Now
FTA5N50	500	4.5	1.25	TO-220F	Ballast, Inverter	Now
FTP5N50	500	4.5	1.25	TO-220	Ballast, Inverter	Now
FTA8N50	500	8	0.8	TO-220F	Ballast, Inverter	Now
FTP8N50	500	8	0.8	TO-220	Ballast, Inverter	Now



MOSFET Product Lines (2)

Part Number	Voltage (V)	Current (A)	Rdson (Ohm)	Package	Application	Mass Production
FTH14N50	500	14	0.4	TO-3P	Telcom, PFC	Now
FTW14N50	500	14	0.4	TO-247	Telcom, PFC	Now
FTU1N60	600	1.5	9.5	TO-251	Charger, Adaptor	Now
FTA2N60	600	2.2	4.4	TO-220F	Charger, Adaptor	Now
FTA4N60	600	4	2.2	TO-220F	Charger, Adaptor	Now
FTA6N60	600	6.2	1.2	TO-220F	Adaptor, SMPS	Now
FTKZ3N65	650	0.5	15	TO-92	Charger	Q1/07
FTU1N65A	650	1	12	TO-251	Charger, Adaptor	Now
FTU1N65	650	1.5	9.5	TO-251	Charger, Adaptor	Now
FTU1N65B	650	1.6	8	TO-251	Charger, Adaptor	Now
FTA2N65	650	2.2	4.4	TO-220F	Charger, Adaptor	Now
FTD2N65	650	2.2	4.6	TO-252	Charger, Adaptor	Now
FTU2N65	650	2.2	4.6	TO-251	Charger, Adaptor	Now
FTA4N65	650	4	2.2	TO-220F	Charger, Adaptor	Now
FTP4N65	650	4	2.2	TO-220	Charger, Adaptor	Now
FTA6N65	650	6	1.25	TO-220F	Adaptor, SMPS	Now
FTA10N65	650	10	0.8	TO-220F	Adaptor, SMPS	Now

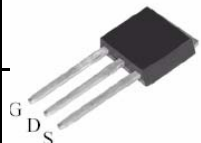
Through-Hole Selection Guide

	TO-92	TO-251		TO-220/TO-220F										TO-3P/TO-247		
	0.5A	1A	2A	2A	4A	5A	6A	8A	9A	10A	18A	60A	84A	110A	14A	
650V	<u>FTKZ3N65</u>	<u>FTU1N65</u>	<u>FTU2N65</u>	<u>FTA2N65</u>	<u>FTA4N65</u>		<u>FTA6N65</u>			<u>FTA10N65</u>						
		<u>FTU1N65A</u>			<u>FTP4N65</u>											
600V				<u>FTA2N60</u>	<u>FTA4N60</u>		<u>FTA6N60</u>									
						<u>FTP5N50</u>		<u>FTP8N50</u>								<u>FTW14N50</u>
500V																<u>FTH14N50</u>
							<u>FTA6N40</u>			<u>FTA10N40</u>						
400V							<u>FTP6N40</u>			<u>FTP10N40</u>						
																
250V-200V								<u>FTP8N25</u>	<u>FTA9N20</u>	<u>FTA18N20</u>						
								<u>FTP8NS25</u>	<u>FTP9N20</u>	<u>FTP18N20</u>						
75V-60V												<u>FTP18N06</u>	<u>FTP11N08</u>	<u>FTP8N06</u>		
												<u>FTP16N06</u>	<u>FTP12N06</u>			

SMD Selection Guide

	TO-252			TO-263										
	1A	2A	9A	2A	4A	5A	6A	8A	9A	10A	18A	60A	84A	110A
650V	<u>FTD1N65</u>	<u>FTD2N65</u>												
600V	<u>FTD1N60</u>	<u>FTD2N60</u>												
500V														
400V														
250V-200V			<u>FTD9N20</u>								<u>FTB18N20</u>			
75V-60V														

More SMD products are underway!

Adaptor/Charger Applications

Input
AC: 90V~264V

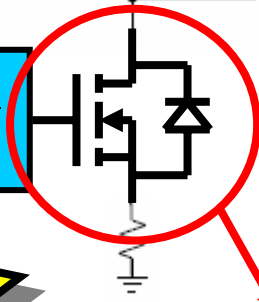
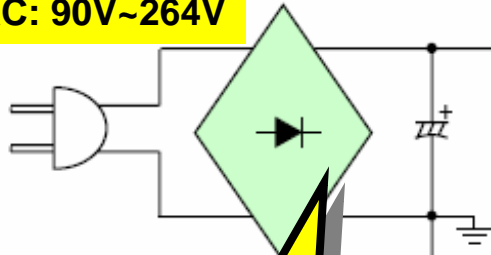

Snubber Circuit

Shottok Diode

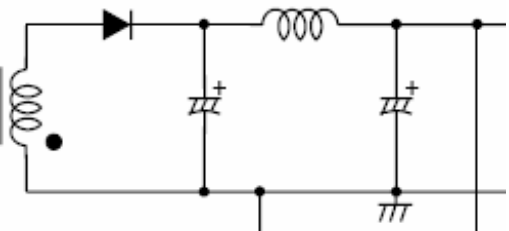

Output:
DC: 3.3V/5V/6V
/9V/12V/19V



**650V Rating
To Prevent
Avalanche
Failure !!!**

- FTU1N65 (<3W)
- FTU2N65 (<6W)
- FTA2N65 (<10W)
- FTP2N65 (<10W)
- FTA4N65 (<20W)
- FTP4N65 (<20W)
- FTA6N65 (<40W)
- FTP6N65 (<40W)
- FTA10N65 (<60W)

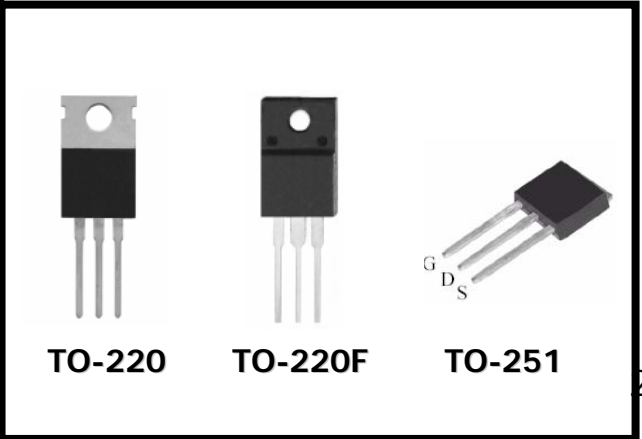

- **High Voltage Spike at Startup or Transient**
 - **650V MOSFET to prevent over-voltage failure**



Adaptor/Charger Applications

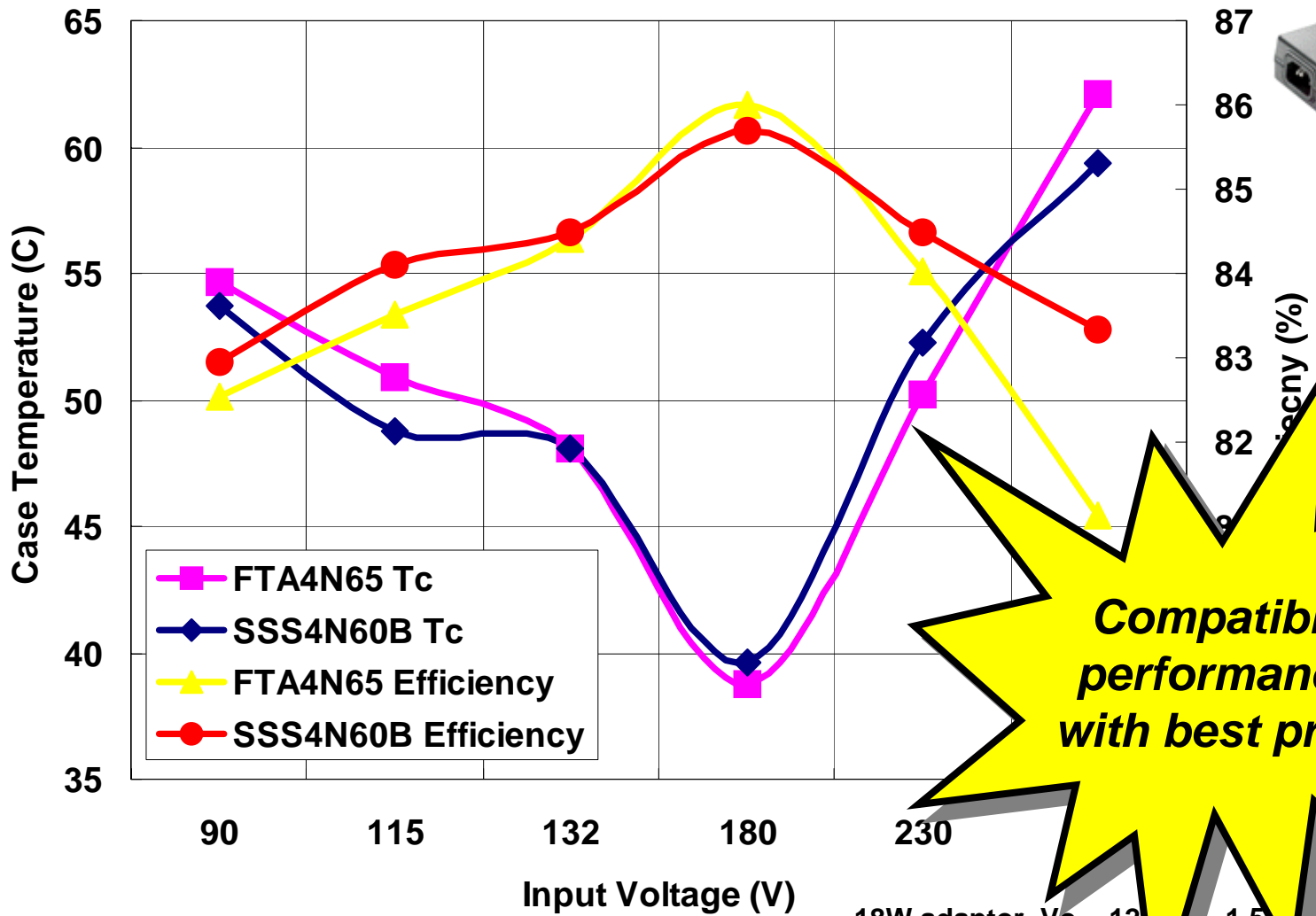

Compatible performance with best price

Adaptor System Solutions

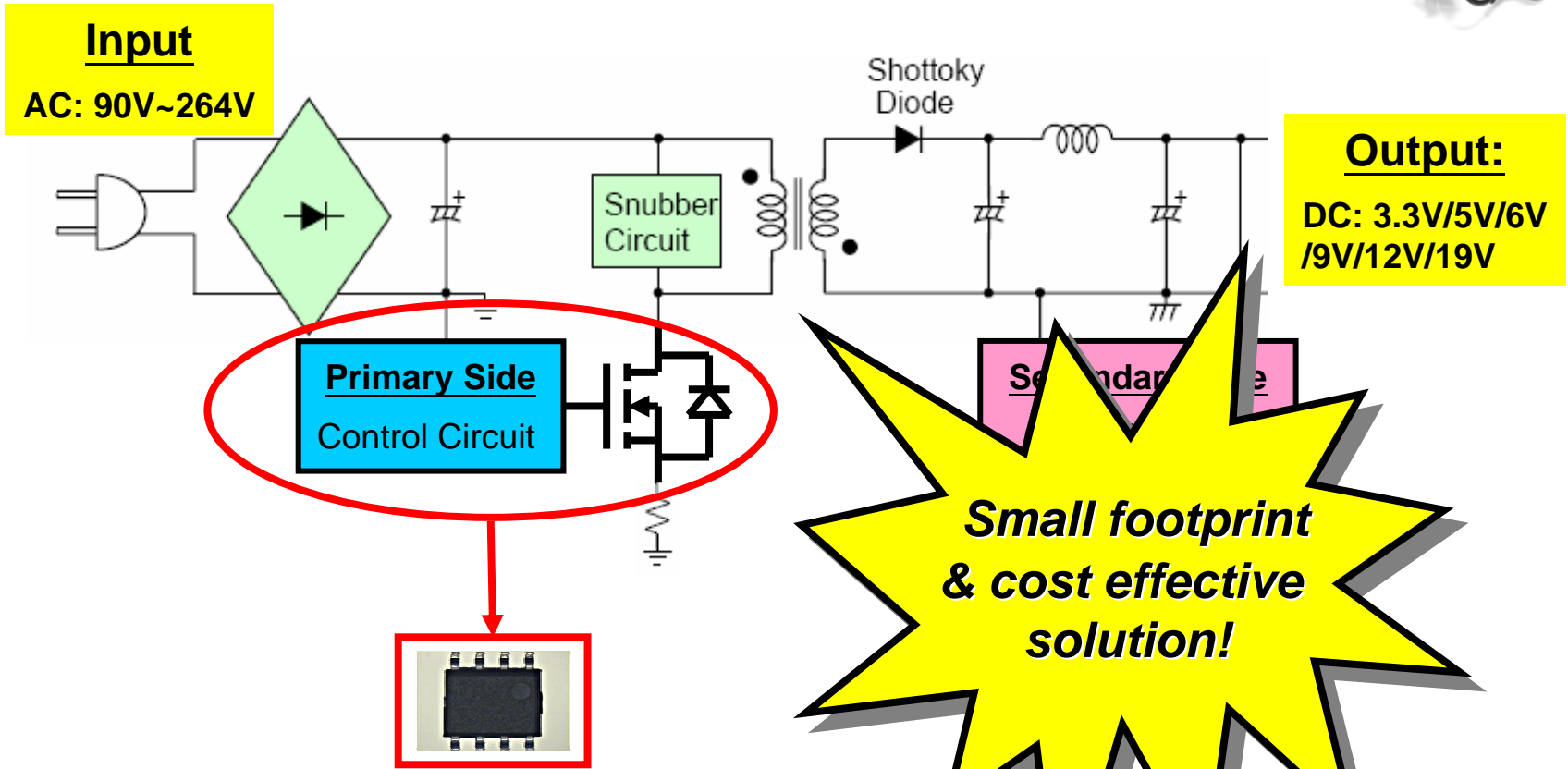

Standby Power Applications

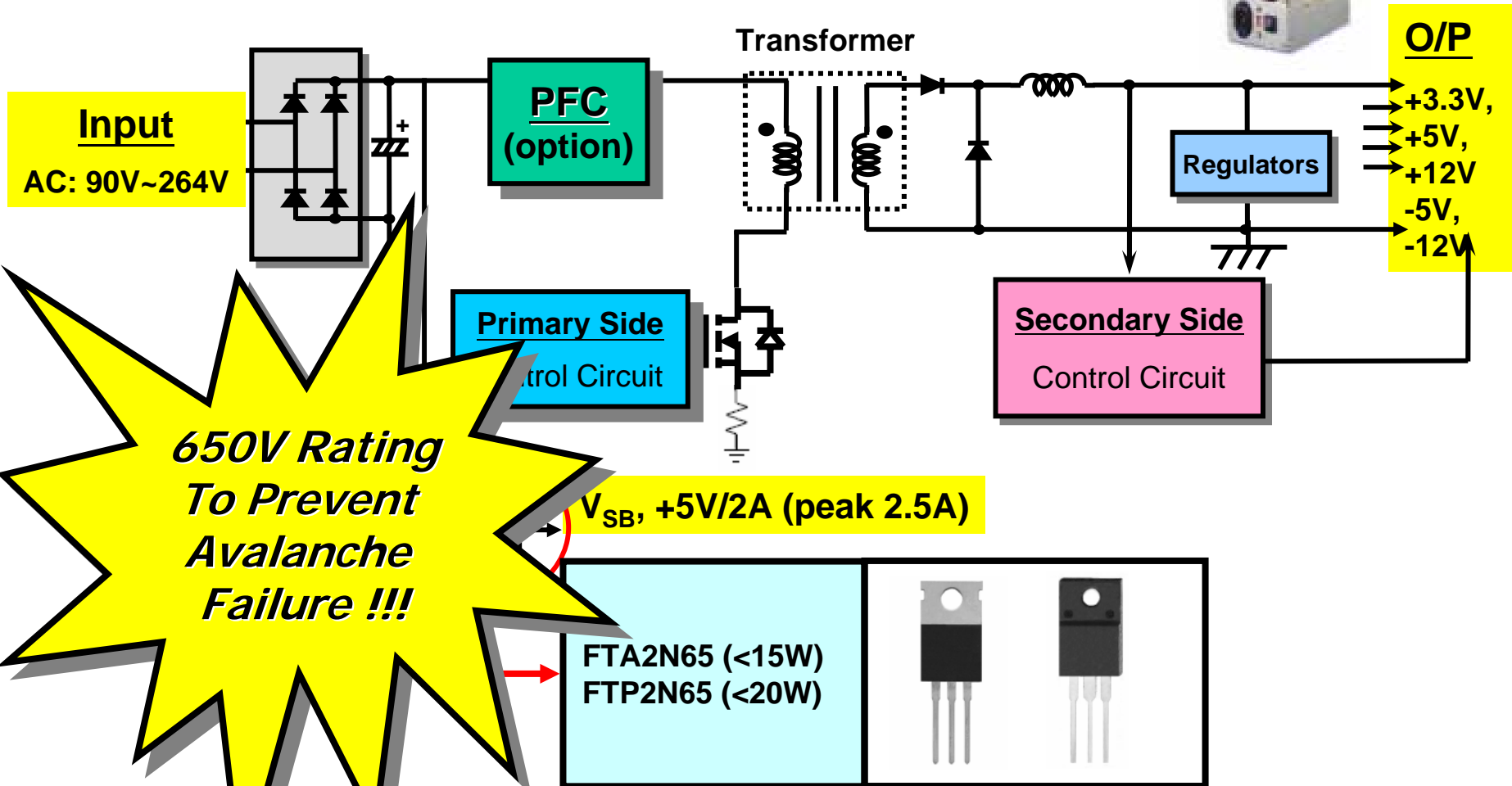

Ballast Applications

Input

AC: 90V~264V

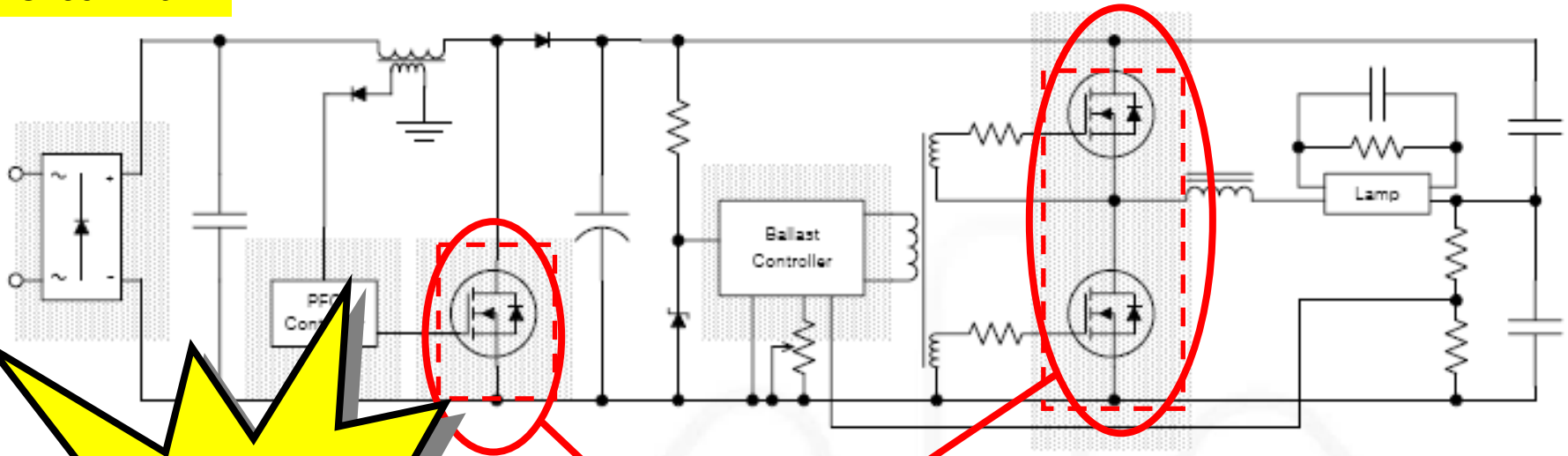

**Enhanced
Thermal
Performance.**

FTP6N40
FTP10N40
FTP5N50
FTP8N50



Outgoing-Quality Control (OQC)

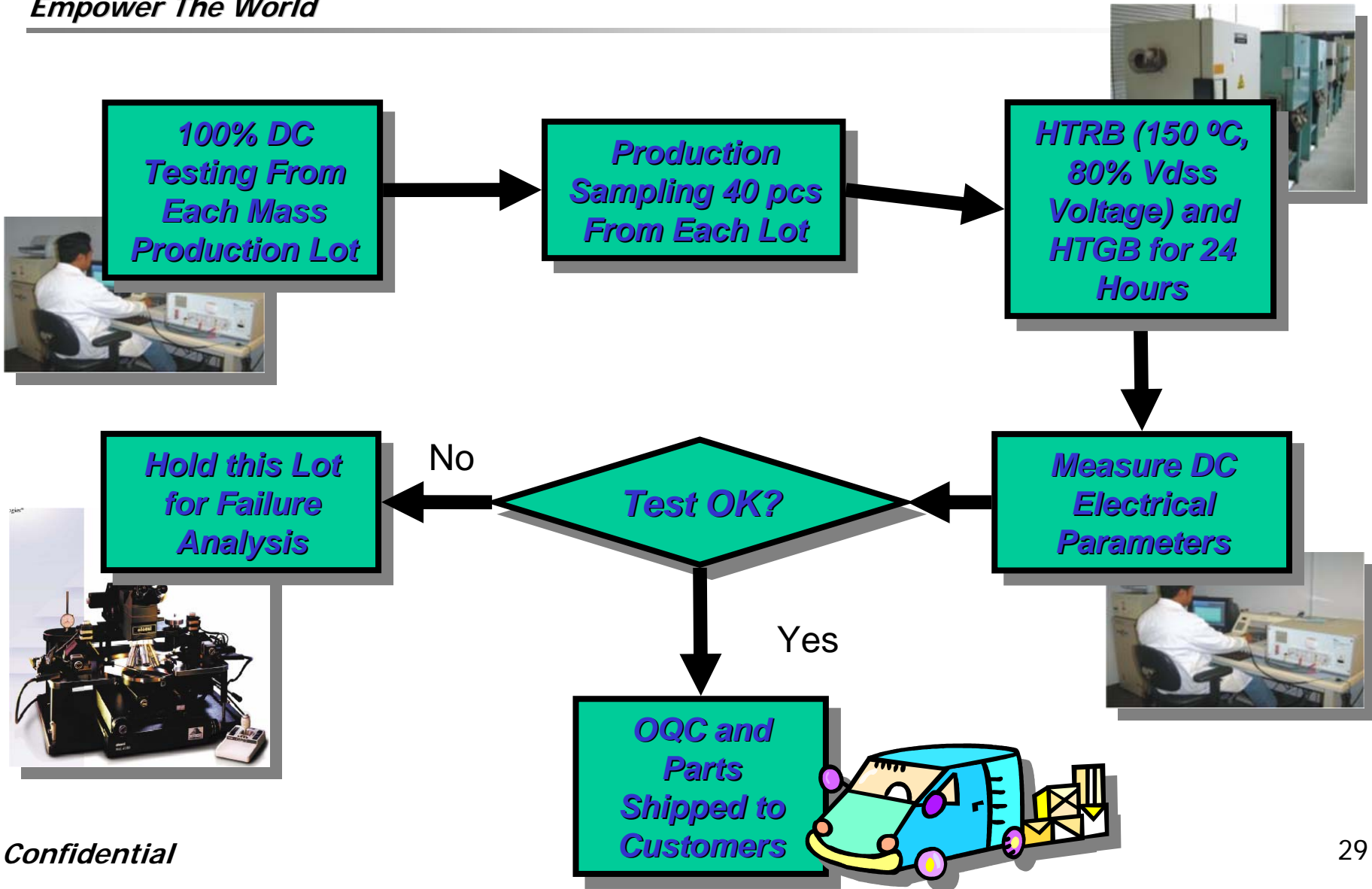

- **Robust Testing on all Finished Devices**

- **100% DC Parametric Testing at 25 °C**

- **100% UIS Test**

- **Reliability Sampling on all Production Lots**

- **Most of the MOSFET suppliers sampled testing periodically, not on every part number, but on packaging types**

we perform sampled testing on *EVERY PRODUCTION* WITH 150 °C AND 80% V_{dss} Rated Voltage



Highest standard in industry

Mass Production Testing

Operation, MOSFET	Sample Size	Measurement Tool	Control Method
Unclamped Inductive Switching, UIS	100% running	ITC UIS Tester	Pass / Fail
delta Vsd, (die attach test)	100% running	Tesec delta Vsd Tester	SPC
BVdss @ 250uA	100% running	Tesec Spectra	SPC
Idss @ 80% Rated Voltage	100% running	Tesec Spectra	SPC
Idss @ Rated Voltage	100% running	Tesec Spectra	SPC
g _{fs} (th) @ 10 uA	100% running	Tesec Spectra	SPC
	100% running	Tesec Spectra	SPC
	100% running	Tesec Spectra	SPC
	100% running	Tesec Spectra	SPC
	100% running	Tesec Spectra	SPC

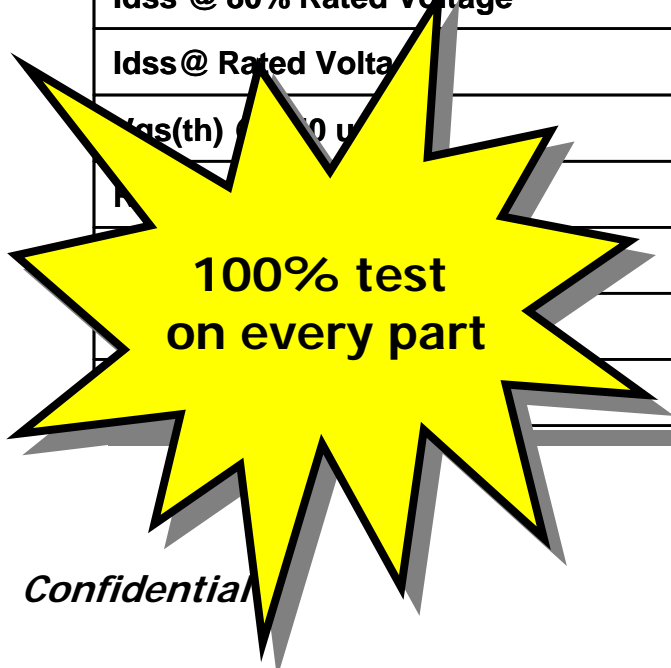

**100% test
on every part**



Empower The World

Reliability Procedures

Step	Test	Description	Test Conditions	Duration	Parameter measurements @	Quantity
1	TC	Temperature Cycle Test	TA = -55 °C <-> 25 °C <-> +150 °C (air to air), t = 15 – 5 – 15 min. / cycle, Bias = None.	1000 Cycles	0, 250, 500, & 1000 Cycles	3 lots x 77 devices per lot
2	PCT	Pressure Cooker Test, also known as Autoclave Test	TA = 121 °C +/- 2 °C, RH = 100%, P = 15PSIG, Bias = None	96 Hours	0 & 96 Hours	3 lots x 77 devices per lot
3	H3TRB	High Temperature Humidity Bias Test	TA = +85°C, RH = 85%, Reverse Bias = Specification Limit X 0.8, or 100volts, which ever is less	1000 hours	0, 168, 500, & 1000 Hours	3 lots x 77 devices per lot
4	HTRB	High Temperature Reverse Bias Test	TA = +150/175°C, Reverse Bias = Specification Limit X 0.8.	1000 hours	0, 168, 500, & 1000 Hours	3 lots x 77 devices per lot
5	HTGB	High Temperature Gate Bias Test	TA = +150/175°C, Gate Bias = Specification Limit.	1000 hours	0, 168, 500, & 1000 Hours	3 lots x 77 devices per lot
6	PC	Power Cycle Test	TA = +25 °C <-> +125 °C, Power Dissipation = ~2.5 Watts	3000 Cycles	0, 1000, & 3000 Cycles	3 lots x 77 devices per lot
7	PreCon	Preconditioning & IR Reflow (surface mount packages only)	Preconditioning: TA °C = -40 <-> + 60 °C, 5 Cycles, followed by TA = +125 °C bake, 3 cycles IR reflow, 245/260+5/-0 °C, 10 sec dwell		PreCon to be completed prior to above reliability tests	3 lots x 462 devices per lot

- **ISO Certified Supply Chains**

Epi Wafer Manufacturer: ISO 9001 Certified ISO 14001 Certified QS 9000 Certified Health and Safety Certified	Wafer Foundry: ISO 9001 Certified TS16949 Certified ISO 14001 Certified ISO Guide 25 Certified
Assembly House: ISO 9002 Certified TS 16949 Certified ISO 14001 Certified QS 9000 Certified	InPower: ISO 9001 Certified ISO 14001 in Process

End of Presentation

Thanks You.