



智弘科技

Jhieh-Hong Technology Co., Ltd.

SPECIFICATION FOR APPROVAL

MODEL NAME : JHT CR1220

JHT P/N : M03030107

DATE : 2011/01/20

REVISION : E

JHT APPROVAL :				
PREPARED		REVIEWED		APPROVED
EE	ME	EE	ME	

Jhieh-Hong Technology Co., Ltd.
 6F, No.9 Wu Chuan Road, Wu-Ku Industrial
 Park Taipei County 248, Taiwan

智弘科技股份有限公司
 台北縣五股工業區五權路9號6樓
www.jht-energy.com

T +886 2 2298 9236
 F +886 2 2290 1657
 E service@jht-energy.com

TITLE	JHT CR1220	REVISED	E
		PAGE	14 / 1

REVISION AND UPDATES

REVISED	DESCRIPTION	DATE
A	First issue	2008/02/04
B	REV:B	2009/11/11
C	REV:C	2010/05/05
D	CHANGE JHT LOGO & FORMAT	2010/06/02
E	ADD DATASHEET	2011/01/20

JHT P/N :	M03030107	
-----------	-----------	---

TITLE	JHT CR1220	REVISED	E
		PAGE	14 / 2

1.Applicability:

This specification is applicable to the following product:
Coin type manganese lithium battery CR1220

2.Battery type and ratings:

- 2.1. Battery type:** CR1220
- 2.2. Nominal voltage:** 3.0V
- 2.3. Nominal capacity:** 38mAh (on continuous discharge at 20°C under 62kΩ load to 2.0V end-voltage)
- 2.4 Outer dimensions:** Outer dimensions shall be as shown in Fig. 1, Battery Dimensions.
- 2.5 weight:** 0.8 g
- 2.6 Production country:** China
- 2.7 Guarantee:** 1 year
- 2.8 Terminals:**
 - Materials of Positive electrode:** SUS430+Ni-Plated or SUS430
 - Negative electrode:** SUS430+Ni-Plated or SUS430

3.Quality requirements:

- 3.1 Dimensions:** Dimensions of batteries when tested in accordance with Subparagraph 4.4.1 shall be as shown in Fig. 1. Battery dimensions.
- 3.2 Appearance:** Battery shall have no deformation, dent, stain, leakage and camber or burr on their sealing members, which may adversely affect their appearance, performance and commercial value. There shall be no coatings or other foreign objects on the surface of terminals which may adversely affect actual use or performance of batteries.
- 3.3 Characteristics:**
 - (1) *Open-circuit voltage: Open-circuit voltage of batteries when tested in accordance with Subparagraph 4.4.3 shall meet the requirement set forth in Table 1.*
 - (2) *Closed-circuit voltage: Closed-circuit voltage of batteries when test in accordance with Subparagraph 4.4.4 shall meet the requirements set forth in Table 1.*

[TABLE 1]

TEST ITEMS	TEMPERATURE	INITIAL	AFTER 12 MONTHS	REMARKS
Open-circuit Voltage	20±2°C	3.0V TO 3.4V	3.0V TO 3.4V	
	0±2°C	3.0V TO 3.4V	3.0V TO 3.4V	
Closed-circuit Voltage	20±2°C	3.0V TO 3.4V	3.0V TO 3.4V	Load Resistance 62kΩ. 0.8 Sec.
	0±2°C	3.0V TO 3.4V	3.0V TO 3.4V	

(3) *Service life: Service life of batteries when tested in accordance with Subparagraph 4.4.5 shall meet the requirements set forth in Table 2.*

JHT P/N :	M03030107	
-----------	-----------	---

TITLE	JHT CR1220	REVISED	E
		PAGE	14 / 3

[TABLE 2]

TEST ITEM	TEMPERATURE	INITIAL	AFTER 12 MONTHS	REMARKS
Service Life	20 ± 2°C	830 Hrs. or Longer	790 Hrs. or Longer	Continuous Discharge Under 62 kΩ Load to 2.0V End-Voltage
	0 ± 2°C	780Hrs. or Longer	740Hrs. or Longer	

(4) Service life after storage at high temperature: Service life of batteries when tested in accordance with Subparagraph 4.4.6 shall meet the requirements set forth in Table 3

[TABLE 3]

TEST ITEM	STORAGE TEMP.	STORAGE PERIOD	REQUIREMENT	REMARKS
Service Life After Storage At High Temperature	60 ± 2°C	20 Days	790Hrs Minimum	Continuous Discharge At 20 ± 2°C Under 62kΩ Load To 2.0V End-Voltage After Storage.

(5) Leakage characteristics: Batteries when tested in accordance with Subparagraph 4.5.1 shall have no leakage.

[TABLE 4]

TEST ITEM	REQUIREMENT	TEST CONDITIONS
Leakage Characteristics	No Leakage	Temperature: 45 ± 2°C, Relative Humidity: 75% Storage: 30 Days Shall Be Inspected By Visual Means

(6) Self-discharge: Self-discharge of batteries when tested in accordance with Subparagraph 4.5.2 shall be as set forth in Table 5.

[TABLE 5]

TEST ITEM	REQUIREMENT	TEST CONDITIONS
Self-discharge	5% or Below	Continuous Discharge Under 62kΩ Load To 2.0V End-voltage After 12 Months Storage At 20°C. (To Obtain From The Mean Value Of The Same Lot)

4. Testing:

4.1 Test conditions:

4.1.1 Initial test :Initial test must be done within 1 months from delivery

JHT P/N :	M03030107	
-----------	-----------	---

TITLE	JHT CR1220	REVISED	E
		PAGE	14 / 4

4.1.2 Temperature and humidity: Unless otherwise specified elsewhere, tests shall be conducted at ordinary temperature ($20 \pm 2^\circ\text{C}$) and ordinary humidity ($65 \pm 5\% \text{RH}$).

4.2 Storage of test specimen batteries:

- 4.2.1 Specimen batteries to be tested shall be kept at the ambient temperature of 25°C or below and at the relative humidity of 75% or below.
- 4.2.2 Storage at less than -20°C can deform the plastic parts and may cause a leakage.
- 4.2.3 To prevent self-discharge caused by corrosion or decrease of insulation, humidity during storage shall be less than 75%RH without dewing on battery.

4.3 Measuring instruments and devices:

- 4.3.1 Dimensions: Outer micrometers specified in JIG26-95, dial gauges specified in JIS B 7503, and vernier callipers specified in JIG30-92 or those having equal or better accuracy shall be used.
- 4.3.2 DC voltmeters: The tolerance shall be $\pm 0.01\text{V}$ and the input resistance rating shall be 10M or more.
- 4.3.3 Load resistance: Load resistance shall include resistance throughout external circuits, and its tolerance shall be $\pm 0.5\%$.

4.4 Test methods:

- 4.4.1 Dimensions: Dimension shall be measured with instruments specified in Subparagraph 4.3.1 above, provided that either one or both sides of such instruments shall be insulated in measuring the overall height of the batteries.
- 4.4.2 Appearance: Appearance of batteries shall be inspected by visual means.
- 4.4.3 Open-circuit voltage: Test specimen batteries shall be kept for 8 hours or longer at the ambient temperature specified in Table 1, and then the voltage between both terminals shall be measured at the same ambient temperature with a voltmeter as specified in Subparagraph 4.3.2.
- 4.4.4 Closed-circuit voltage: Test specimen batteries shall be kept for 8 hours or longer at the ambient temperature specified in Table 1. and then the voltage between both terminals shall be measured with a voltmeter as specified in Subparagraph 4.3.2 while the specified load is connected between both terminals at the same ambient temperature as specified above; provided that the measured value shall be based on meter reading taken 8 seconds after the circuit is closed.
- 4.4.5 Service life: Test specimen batteries shall be kept for 8 hours or longer at the ambient temperature specified in Table 2. and shall then be continuously discharged at the same ambient temperature and through the specified load resistance. The discharge shall be continued until the terminal voltage of the test specimens falls below the discharge end-point voltage of 2.0V, and the time during which the

JHT P/N :	M03030107	
-----------	-----------	---

TITLE	JHT CR1220	REVISED	E
		PAGE	14 / 5

terminal voltage has been maintained equal to and above the discharge end-point voltage shall be taken as the service life.

4.4.6 Service life after high-temperature storage: Test specimen batteries, after having been stored at the temperature and period specified in Table 3, shall be kept for 12 hours or longer at ordinary temperature (20±2°C) and at ordinary humidity (65±20%RH) and shall then be continuously discharged through the load resistance 15K at ambient temperature of 20±2°C. The discharge shall be continued until the voltage falls below the discharge end-point voltage of 2.0V, and the time during which the voltage has been maintained equal to and above the discharge end-point voltage shall be taken as the service life.

4.5 Other tests: Tests specified below shall be conducted as required. Except as specified in this paragraph. Test methods be in accordance with the provisions of Paragraph 4.4.

4.5.1 Electrolyte leakage test: Test specimen batteries shall be examined for electrolyte leakage while they are kept at ordinary temperature and at ordinary humidity after having been stored at the temperature, humidity and period specified in Table 4.

4.5.2 Self-discharge: Test specimen batteries which have been stored for 12 month at the ambient temperature of 20±2°C and at the relative humidity of 65±20% shall be tested for service life in accordance with the method specified in Subparagraph 4.4.5

Self-discharge shall be determined in the following manner:

$$\text{Self-discharge rate (\%)} = \frac{X1 - X2}{X1} \times 100\%$$

X1: Average initial discharge life of batteries of the same lot

X2: Average discharge life after storage

4.6 Important Notes(Warranty)

4.6.1 The batteries are warranted to conform to the description contained in this specifications for a period of twelve(12) months from the ex-factory date and any claim by customer (apparatus manufacturer or distributor) must be made within such period. During that warranty period, if the batteries are proved to become defective, non-defective and conforming batteries will be supplied in due course at sole expense of Jhieh hong upon Jhieh hong's own determination that this is apparently caused by negligence of Jhieh hong.

4.6.2 This product, if defective in materials or workmanship, will be replaced free of charge, when returned to Jhieh hong Technology co., ltd.

Replacement is the sole obligation under this warranty. This warranty expressly excludes incidental and consequential damages caused by use of, or inability to use, this product.

4.6.3 When customer does any work on the battery except instructions in this specifications, for example wire is soldered to the tab or battery surface directly, Jhieh hong Technology co., ltd.

JHT P/N :	M03030107	
-----------	-----------	---

TITLE	JHT CR1220	REVISED	E
		PAGE	14 / 6

Can not warrant any battery performance including safety and the customer shall undertake the responsibility of all damage caused by this battery.

4.6.4 Confirm and assure the matching and reliability of batteries on actual set or unit application with customer's responsibility

4.6.5 In the case of the following situation, it will be assured that Jihong Technology co., ltd. does not take responsibility

- (1) When the appropriate handling, use, installation, or examination of batteries were not carried out.
- (2) When the instructions, attentions or warning mentioned in this specification were not followed
- (3) When the rational instructions or advice of Jihong Technology co., ltd. were not followed

4.6.6 When this specifications is not returned in 6 months from issued date. This specification is deemed to be.

5. Notice

- 5.1 Keep away heat or fire, Heating the battery above 100 degree may cause leakage, fire or explosion.
- 5.2 Do not place near the boiler or radiator, nor expose to the direct sunlight
- 5.3 Do not try to disassemble the battery or battery pack.
- 5.4 Do not short-circuit the battery, Do not handle or store with metallic materials which can cause short-circuit.
- 5.5 Do not dispose the with metallic materials which can cause short-circuit.
- 5.6 Do not dispose the battery into water or constant with water.
- 5.7 Do not throw the battery or drop into ground.
- 5.8 Do not directly solder onto the battery.
- 5.9 Do not connect battery with reversed poles.
- 5.10 Do not use the battery in the unspecified applications.
- 5.11 Do not use the battery mixed with primary cells or other kinds rechargeable battery.
- 5.12 Please read the instruction carefully before use.

6. Markings:

6.1 Markings on batteries:

- 6.1.1 Battery type: CR1220
- 6.1.2 Brand of battery: JHT
- 6.1.3 Polarity: + [(-) shall not be indicated]
- 6.1.4 Manufacturing marks: The year and month of production shall be marked on the negative (-) terminal side

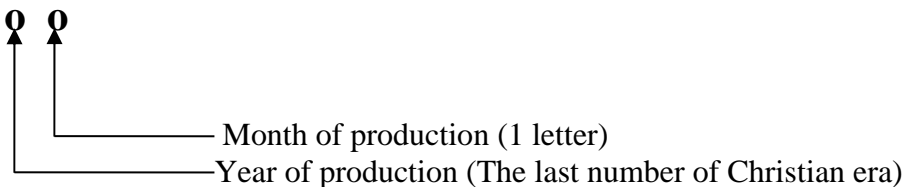

JHT P/N :	M03030107	
-----------	-----------	---

TITLE	JHT CR1220	REVISED	E
		PAGE	14 / 7

[[Example] 81..... Manufactured in January 2008

8X Manufactured in October 2008

8Y Manufactured in November 2008

8Z Manufactured in December 2008

Month of production.

- January to September -- 1- 9

- Oct, Nov, Dec, -----X, Y, Z

JHT P/N :	M03030107	
-----------	-----------	---

TITLE	JHT CR1220	REVISED	E
		PAGE	14 / 8

RATINGS OF MANGANESE DIOXIDE LITHIUM BATTERY

(TYPE: CR1220)

<i>CLASSIFICATION</i>		<i>MANGANESE DIOXIDE LITHIUM PRIMARY BATTERY</i>
<i>BATTERY SYSTEM</i>		<i>COIN TYPE MANGANESE DIOXIDE LITHIUM BATTERY</i>
<i>BATTERY TYPE</i>		CR1220
<i>NOMINAL VOLTAGE</i>		3.0V
<i>NOMINAL CAPACITY</i>		38mAh (ON CONTINUOUS DISCHARGE UNDER 62K Ω load to 2.0V end-point)
<i>STANDARD DISCHARGE CURRENT</i>		0.1mA
<i>WEIGHT</i>		0.8g
<i>TERMINALS</i>	<i>CAP TERMINAL CASE TERMINAL</i>	SUS430+Ni-Plated or SUS430 SUS430+Ni-Plated or SUS430
<i>OUTER DIMENSIONS</i>	<i>DIAMETER OVERALL HEIGHT</i>	$\phi 12.5(+0/-0.3)mm$ 2.0(+0/-0.2)mm
<i>USABLE TEMPERATURE RANGE</i>		-20 °C ~ +70 °C
<i>STORAGE TEMPERATURE RANGE</i>		0 °C ~ 30 °C
<i>STORAGE HUMIDITY RANGE</i>		40% ~ 75%

JHT P/N :	M03030107	JHT POWER IN PARTNERSHIP
-----------	-----------	------------------------------------

TITLE	JHT CR1220	REVISED	E
		PAGE	14 / 9

The Appearance Of CR1220



The Dimensions Of CR1220

Fig.1

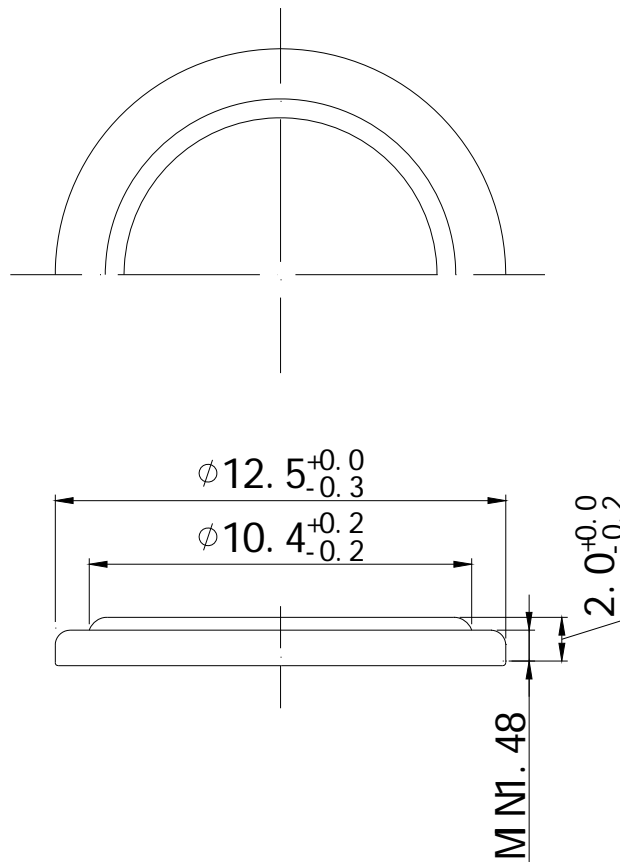

JHT P/N :	M03030107	JHT POWER IN PARTNERSHIP
-----------	-----------	------------------------------------

TITLE	JHT CR1220	REVISED	E
		PAGE	14 / 10

Lithium manganese dioxide battery

CR1220

Specifications

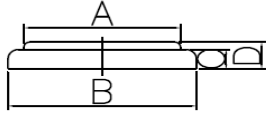
Nominal Voltage	3V	Dimensions (mm) 	A	$\phi 10.4$
Nominal Capacity	38(mAh)		B	$\phi 12.5^{+0.0}_{-0.3}$
Continuous standard load	62(K Ω)		C	1.48(Ref.)
Operating temperature	-20~70 $^{\circ}$ C		D	$2.0^{+0.0}_{-0.2}$
Weight	0.8(g)			

Discharge characteristics

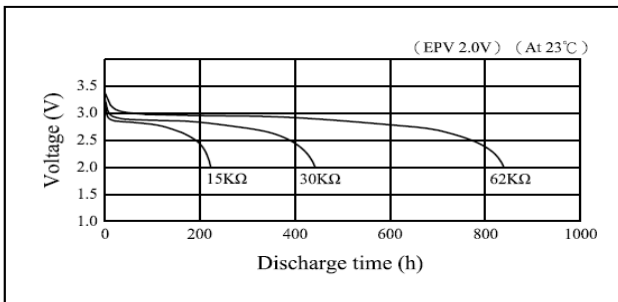

Temperature characteristics

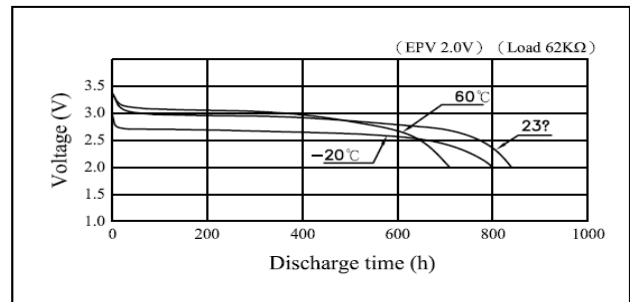

Load vs. Operating voltage

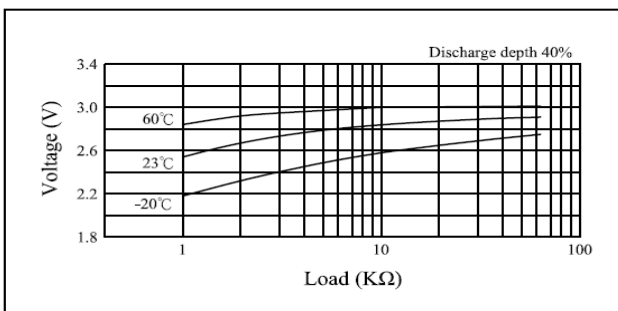

Load vs. Capacity

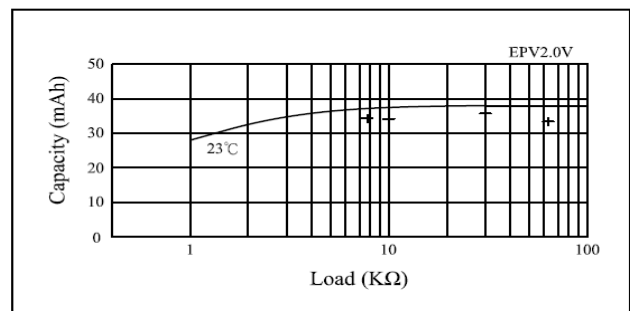

Pulse discharge characteristics

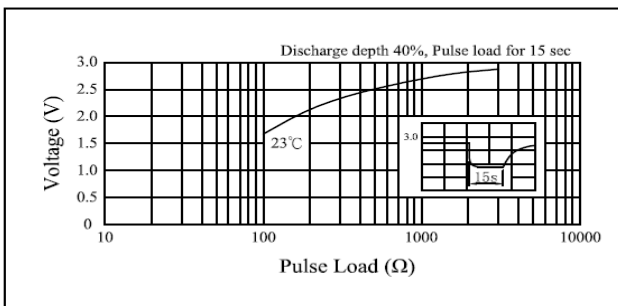

Storage characteristics

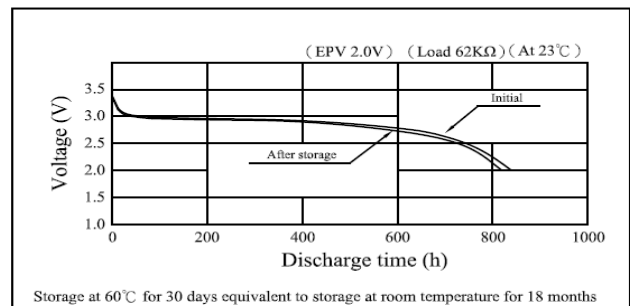

JHT P/N :	M03030107	
-----------	-----------	---

TITLE	JHT CR1220	REVISED	E
		PAGE	14 / 11

Warnings

7.1 Precautions in Circuit Design for back-up Use

This is a primary battery and cannot be charged. If used in memory or RTC back-up applications, be sure to use diodes to prevent charging from the main power source or other batteries, and protective resistance to regulate the current as shown in the figure below. Note that the points described below should be taken into careful consideration when selecting diodes and protective resistance.

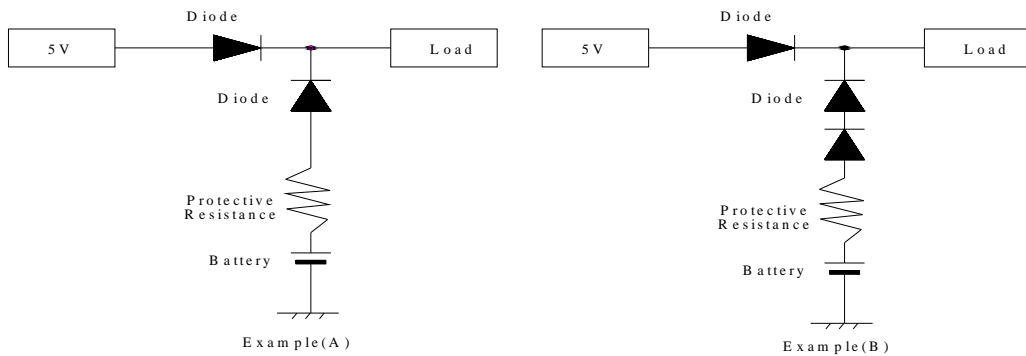

7.2 Supplied voltage to load.

Because a diode and a resistance generate the voltage drop on operating, please take into consideration these voltage drops for supplied voltage to load.

7.3 Using diodes to prevent charging

Please choose diodes with leak current as small as possible. Please keep the charged capacity due to leak current to within 1% of nominal capacity.

7.4 Using and setting protective resistance

Protective resistance is used to prevent the battery from being charged by large surges of current during diode failure. Please set the resistance so that the maximum current shown in the right table is not exceeded. For example, say a CR2032 battery is used in sample circuit (A) in combination with a main power source 5 volt. Since the permitted charge current is 10mA and this battery's voltage is 3V, let resistance be $R \geq (5V-3V)/10mA=0.2k \text{ ohm}$, meaning that at least 0.2k ohm is required.

Type	Maximum current
CR1220	2.5 mA
CR3032	15 mA
CR2450	15mA
CR2354	12mA
CR2330	10mA
CR2032	10mA
CR2025	10mA
CR2016	10mA

JHT P/N :	M03030107	
-----------	-----------	--

TITLE	JHT CR1220	REVISED	E
		PAGE	14 / 12

CR1220 Packing Details

⑤	⑩
④	⑨
③	⑧
②	⑦
①	⑥

⑤	⑩
④	⑨
③	⑧
②	⑦
①	⑥

I	II
III	IV

Remarks: 15 trays of with top cover plus manual instruction and PVC wrapped.

x 20

x 15=300pcs/pack

20pcs/tray

Model	Net Weight (Kg)	Gross Weight (Kg)
CR1220	4.8	7.5

Remarks:

1. Carton Size: 340(L)*280(W)*210(H) mm
2. Total:6000 pcs /Carton
3. Each carton contains a moistureproof paper located on top & bottom .

uni t : mm

Box packing dimensions and drawing

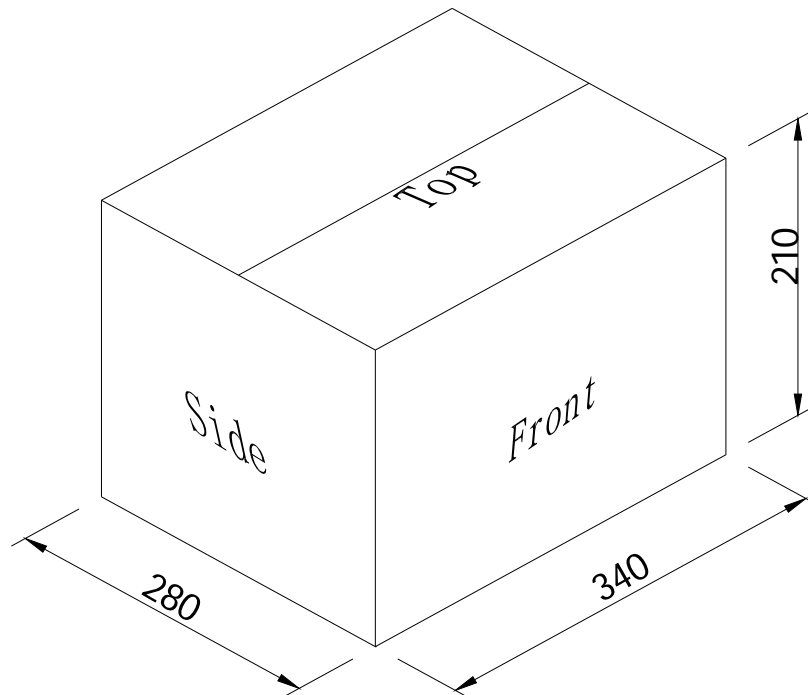

JHT P/N :	M03030107	
-----------	-----------	--

TITLE	JHT CR1220	REVISED	E
		PAGE	14 / 13

Box External Marking

Side Marking (Right side)

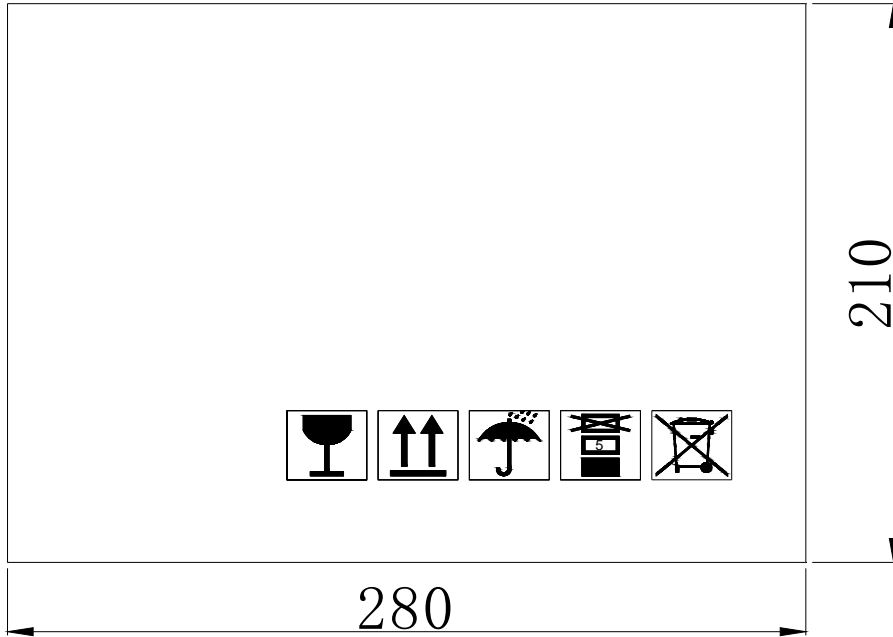

Side Marking (Left side)

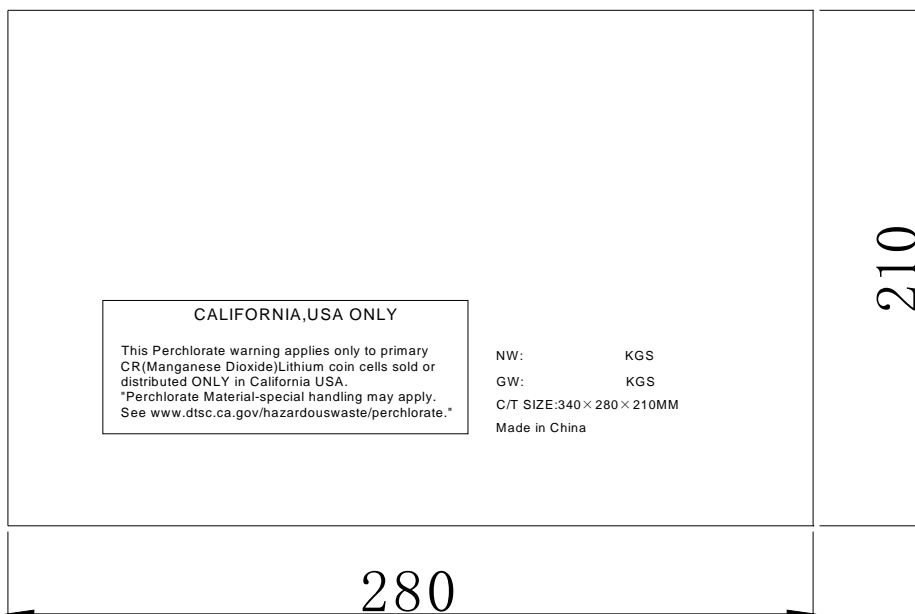

JHT P/N :	M03030107	JHT POWER IN PARTNERSHIP
-----------	-----------	------------------------------------

TITLE	JHT CR1220	REVISED	E
		PAGE	14 / 14

Front Marking & Back Marking

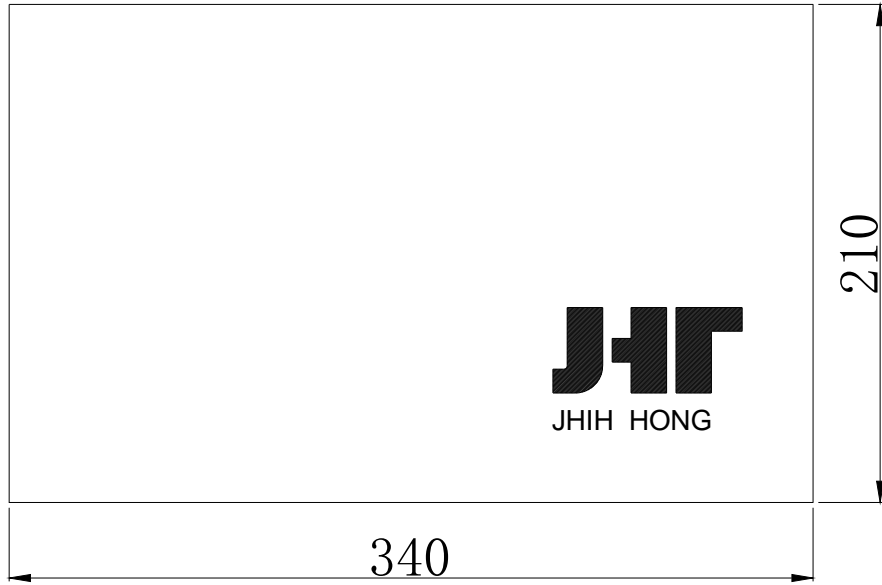

Top Marking

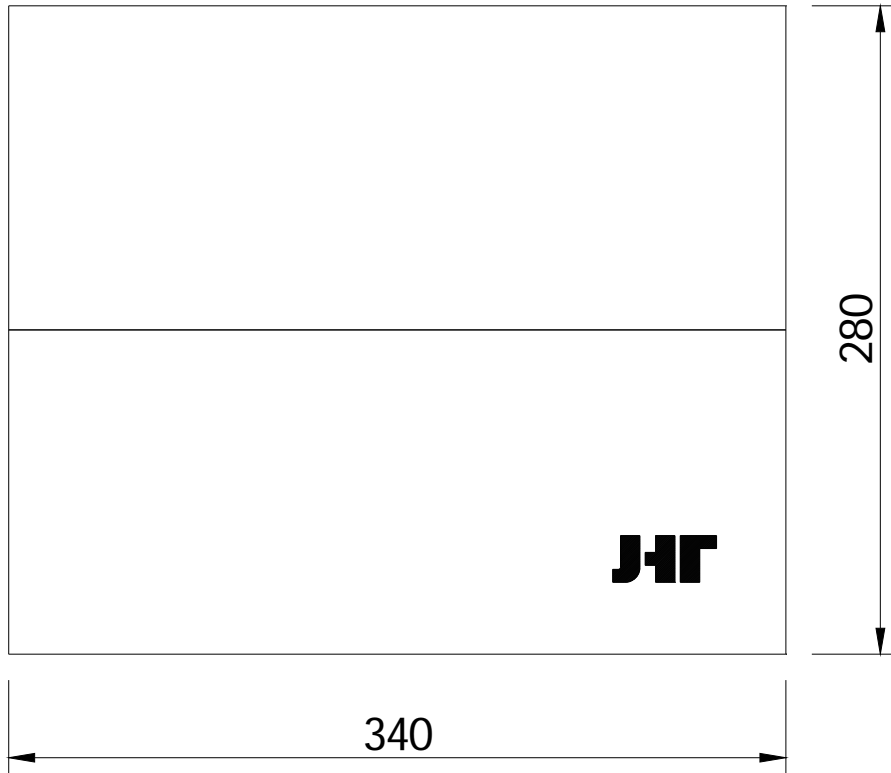

JHT P/N :	M03030107	JHT POWER IN PARTNERSHIP
-----------	-----------	------------------------------------