

# 3

## SURFACE MOUNT ALUMINUM ELECTROLYTIC CAPACITORS

---

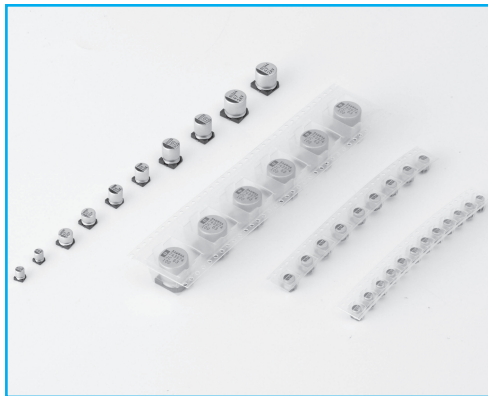

# SURFACE MOUNT ALUMINUM ELECTROLYTIC CAPACITORS

## PART NUMBER SYSTEM

### ● Part Number System

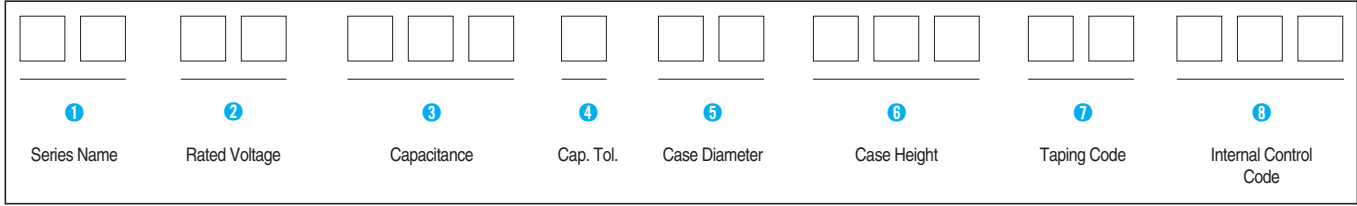

**1** Series Name  
See page 4.

**2** Rated Working Voltage

<b>WV</b>	<b>4</b>	<b>6.3</b>	<b>10</b>	<b>16</b>	<b>25</b>	<b>35</b>	<b>50</b>
<b>Code</b>	0G	0J	1A	1C	1E	1V	1H
<b>WV</b>	<b>63</b>	<b>100</b>	<b>160</b>	<b>200</b>	<b>250</b>	<b>400</b>	<b>450</b>
<b>Code</b>	1J	2A	2C	2D	2E	2G	2W

**6** Case Height  
ex) 5.3mm 005  
5.8mm 006  
6.2mm 06B  
7.7mm 07K  
10mm 010  
13.5mm 13M

**7** VR (Reel Type)

**3** Capacitance

ex) 0.47 $\mu$ F 474  
4.7 $\mu$ F 475  
47 $\mu$ F 476  
470 $\mu$ F 477  
4700 $\mu$ F 478

**4** Capacitance Tolerance

<b>Tolerance (%)</b>	±20
<b>Code</b>	M

**5** Case Diameter

ex)  $\varnothing$ 4 04  
 $\varnothing$ 5 05  
 $\varnothing$ 6.3 6L  
 $\varnothing$ 8 08  
 $\varnothing$ 10 10  
 $\varnothing$ 12.5 12

● Taping Specifications for Chip Type Capacitors

● Carrier Tape

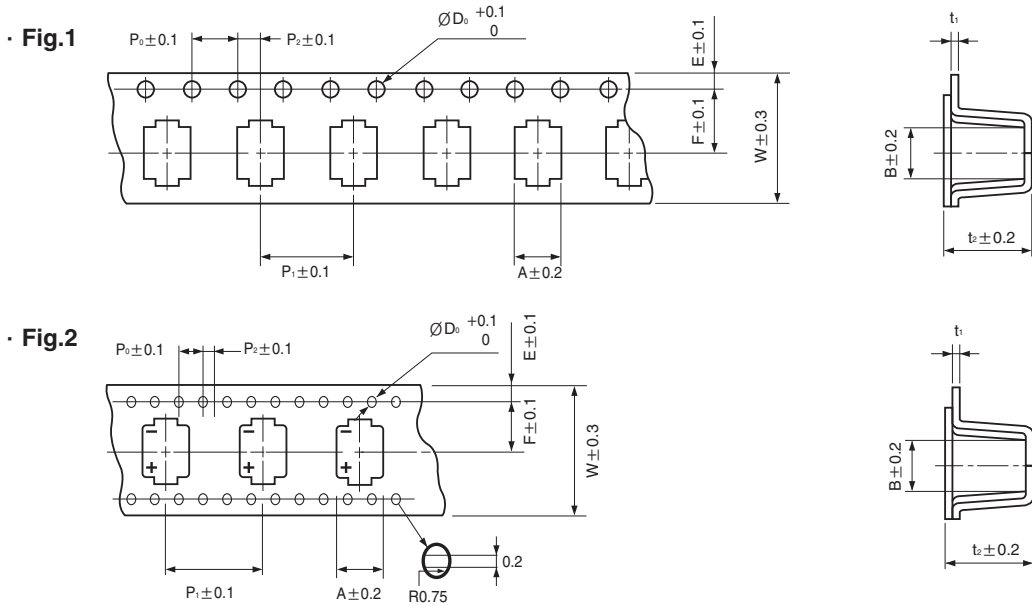

ØD×L	A	B	ØD <sub>0</sub>	E	F	P <sub>0</sub>	P <sub>1</sub>	P <sub>2</sub>	t <sub>1</sub>	t <sub>2</sub>	W	Fig.	
4 × 5.3	4.7	4.7	1.5	1.75	5.5	4.0	8.0	2.0	0.4	5.7	12.0	1	
5 × 5.3	5.7	5.7	1.5	1.75	5.5	4.0	12.0	2.0	0.4	5.7	12.0		
6.3 × 5.3	7.0	7.0	1.5	1.75	7.5	4.0	12.0	2.0	0.4	5.7	16.0		
6.3 × 5.8	7.0	7.0	1.5	1.75	7.5	4.0	12.0	2.0	0.4	6.3	16.0		
6.3 × 7.7	7.0	7.0	1.5	1.75	7.5	4.0	12.0	2.0	0.4	8.2	16.0		
8 × 6.2	8.7	8.7	1.5	1.75	7.5	4.0	12.0	2.0	0.4	6.8	16.0		
8 × 10	8.7	8.7	1.5	1.75	11.5	4.0	16.0	2.0	0.4	11.0	24.0		
10 × 10	10.7	10.7	1.5	1.75	11.5	4.0	16.0	2.0	0.4	11.0	24.0		
12.5 × 13.5	14.0	14.0	1.5	1.75	14.2	4.0	24.0	2.0	0.5	14.0	32.0		2

● Reel (Taping code : VR)

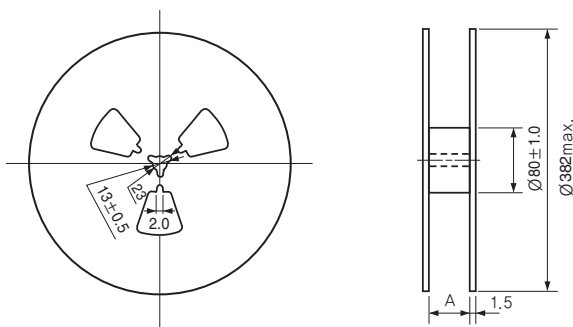

ØD×L	A	ØD×L	Q'ty/Reel(pcs.)	Q'ty/Box(pcs.)
4 × 5.3	14	4 × 5.3	2000	20000
5 × 5.3	14	5 × 5.3	1000	10000
6.3 × 5.3	18	6.3 × 5.3	1000	10000
6.3 × 5.8	18	6.3 × 5.8	1000	10000
6.3 × 7.7	18	6.3 × 7.7	900	9000
8 × 6.2	18	8 × 6.2	1000	10000
8 × 10	26	8 × 10	500	3000
10 × 10	26	10 × 10	500	3000
12.5 × 13.5	34	12.5 × 13.5	200	1000

● Polarity

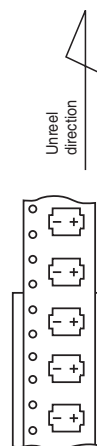

● Recommended Land Size

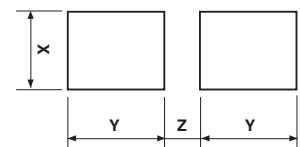

ØD×L	X	Y	Z
4 × 5.3	1.6	2.6	1.0
5 × 5.3	1.6	3.0	1.4
6.3 × 5.3	1.6	3.5	2.0
6.3 × 5.8	1.6	3.5	2.0
6.3 × 7.7	1.6	3.5	2.0
8 × 6.2	2.5	4.0	2.0
8 × 10	2.5	3.5	3.0
10 × 10	2.5	4.0	4.0
12.5 × 13.5	4.0	7.5	7.0

# SURFACE MOUNT ALUMINUM ELECTROLYTIC CAPACITORS

## Reflow soldering method for the chip aluminum electrolytic capacitor

### 1. Recommended conditions for reflow soldering

The chip aluminum electrolytic capacitor is subjected to soldering by reflow method. Temperature and time conditions of reflow soldering shall be set as per each temperature profile shown below as a standard. The following are recommended conditions in the case of reflow soldering method for the chip aluminum electrolytic capacitor.

- (1) The capacitor shall not be subjected to either flow or dip soldering method.
- (2) Avoid soldering twice by reflow. The number of reflow time for chip aluminum electrolytic capacitor shall be once basically. If this type of capacitor has to be inevitably subjected to the reflow twice, enough cooling time between the first and the second reflow (at least more than 30 minutes) shall be taken to avoid the consecutive reflows by all means.
- (3) The touch up work with a soldering iron is allowed after the reflow soldering (Temperature of soldering iron : MAX 400°C, Time : 5 sec.), provided that carefully attention shall be paid lest a soldering iron should directly touch the capacitor body or its resin bottom base.

### 2. RECOMMENDED REFLOW SOLDERING CONDITIONS

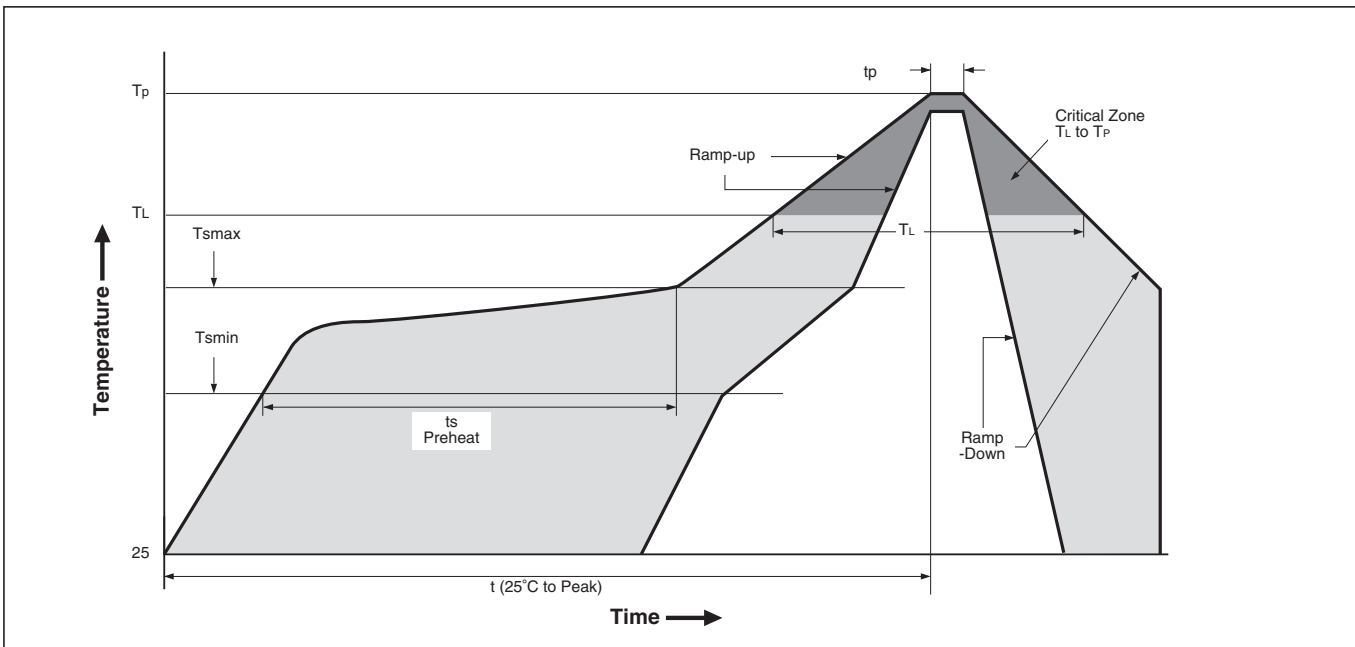

Profile Feature	Soldering condition	
	Ø4 ~ Ø10	Ø12.5
Average Ramp-up Rate (T <sub>L</sub> to T <sub>P</sub> )	3°C / second max.	3°C / second max.
Preheat	Temperature Min. (T <sub>s</sub> min)	150°C
	Temperature Max. (T <sub>s</sub> max)	200°C
	Time (T <sub>s</sub> min to T <sub>s</sub> max)	60 ~ 150 seconds
T <sub>s</sub> max to T <sub>L</sub> -Ramp-up Rate	3°C / second max.	3°C / second max.
Time maintained above	Time (T <sub>L</sub> )	217°C
	Time (t <sub>L</sub> )	60 ~ 90 seconds
Peak/classification Temperature (T <sub>P</sub> )	250°C	240°C
Time within 5°C of actual peak temperature(T <sub>P</sub> )	10 seconds max.	10 seconds max.
Ramp-Down rate	3°C / second max.	3°C / second max.
Time 25°C to peak temperature	8 minute max.	8 minute max.

## SC Chip type, Standard Series

- Chip type higher capacitance in larger case size
- Designed for surface mounting on high density PC board
- Applicable to automatic insertion machine using carrier tape
- Complied to the RoHS directive

Solvent Proof  
WV ≤ 100V

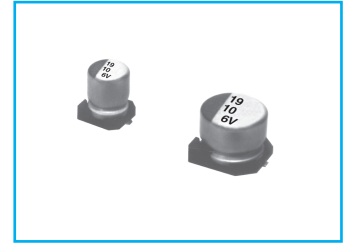

Item	Characteristics																														
Operating temperature range	-40 ~ +85°C																														
Leakage current max.	WV ≤ 100 I = 0.01CV or 3μA whichever is greater (after 2 minutes) WV ≥ 160 I = 0.04CV + 100μA (after 1 minutes)																														
Capacitance tolerance	±20% at 120Hz, 20°C																														
Dissipation factor max. (at 120Hz, 20°C)	<table border="1"> <tr> <td>WV</td> <td>4</td> <td>6.3</td> <td>10</td> <td>16</td> <td>25</td> <td>35</td> <td>50</td> <td>63</td> <td>100</td> <td>160</td> <td>200</td> <td>250</td> <td>400</td> <td>450</td> </tr> <tr> <td>tanδ</td> <td>0.40</td> <td>0.35</td> <td>0.24</td> <td>0.20</td> <td>0.16</td> <td>0.15</td> <td>0.12</td> <td>0.12</td> <td>0.12</td> <td>0.20</td> <td>0.20</td> <td>0.20</td> <td>0.25</td> <td>0.25</td> </tr> </table>	WV	4	6.3	10	16	25	35	50	63	100	160	200	250	400	450	tanδ	0.40	0.35	0.24	0.20	0.16	0.15	0.12	0.12	0.12	0.20	0.20	0.20	0.25	0.25
WV	4	6.3	10	16	25	35	50	63	100	160	200	250	400	450																	
tanδ	0.40	0.35	0.24	0.20	0.16	0.15	0.12	0.12	0.12	0.20	0.20	0.20	0.25	0.25																	
Low temperature characteristics (Impedance ratio at 120Hz)	<table border="1"> <tr> <td>WV</td> <td>4</td> <td>6.3</td> <td>10</td> <td>16</td> <td>25</td> <td>35 ~ 100</td> <td>160 ~ 250</td> <td>400 ~ 450</td> </tr> <tr> <td>Z-25°C/Z+20°C</td> <td>6</td> <td>5</td> <td>4</td> <td>3</td> <td>2</td> <td>2</td> <td>3</td> <td>6</td> </tr> <tr> <td>Z-40°C/Z+20°C</td> <td>12</td> <td>10</td> <td>8</td> <td>6</td> <td>4</td> <td>3</td> <td>6</td> <td>10</td> </tr> </table>	WV	4	6.3	10	16	25	35 ~ 100	160 ~ 250	400 ~ 450	Z-25°C/Z+20°C	6	5	4	3	2	2	3	6	Z-40°C/Z+20°C	12	10	8	6	4	3	6	10			
WV	4	6.3	10	16	25	35 ~ 100	160 ~ 250	400 ~ 450																							
Z-25°C/Z+20°C	6	5	4	3	2	2	3	6																							
Z-40°C/Z+20°C	12	10	8	6	4	3	6	10																							
Load life (after application of the rated voltage for 2000 hours at 85°C)	<table border="1"> <tr> <td>Leakage current</td> <td>Less than specified value</td> </tr> <tr> <td>Capacitance change</td> <td>Within ±20% of initial value (Small size : ±25%)</td> </tr> <tr> <td>tanδ</td> <td>Less than 200% of the specified value</td> </tr> </table>	Leakage current	Less than specified value	Capacitance change	Within ±20% of initial value (Small size : ±25%)	tanδ	Less than 200% of the specified value																								
Leakage current	Less than specified value																														
Capacitance change	Within ±20% of initial value (Small size : ±25%)																														
tanδ	Less than 200% of the specified value																														
Shelf life(at 85°C)	After 1000 hours no load test, leakage current, capacitance and tanδ are same as load life value. The measurement shall be performed at 20°C by the KS C 6503 clause 5.1.																														
Resistance to soldering heat	The following specifications shall be satisfied when the capacitors are restored to 20°C after exposing them at 250°C for 30 seconds. <table border="1"> <tr> <td>Leakage current</td> <td>Less than specified value</td> </tr> <tr> <td>Capacitance change</td> <td>Within ±10% of initial value</td> </tr> <tr> <td>tanδ</td> <td>Less than specified value</td> </tr> </table>	Leakage current	Less than specified value	Capacitance change	Within ±10% of initial value	tanδ	Less than specified value																								
Leakage current	Less than specified value																														
Capacitance change	Within ±10% of initial value																														
tanδ	Less than specified value																														

### ● DRAWING -Series code of SC is "V"

Unit : mm

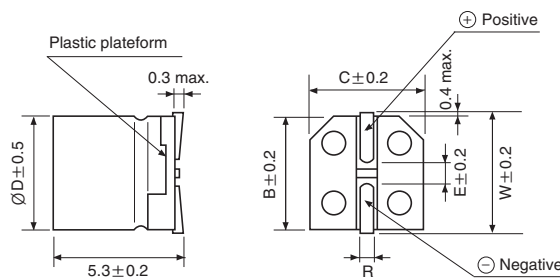
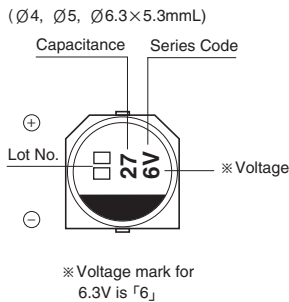

∅D×L	W	A	B	C	E	R
4×5.3	4.8		4.3	4.3	1.0	0.5~0.8
5×5.3	5.8		5.3	5.3	1.4	0.5~0.8
6.3×5.8	7.1		6.6	6.6	2.2	0.5~0.8
6.3×7.7		2.4	6.6	6.6	2.2	0.5~0.8
8×6.2		3.3	8.3	8.3	2.3	0.5~0.8
8×10		2.9	8.3	8.3	3.1	0.8~1.1
10×10		3.2	10.3	10.3	4.5	0.8~1.1
12.5×13.5		4.6	12.8	12.8	4.5	0.8~1.4

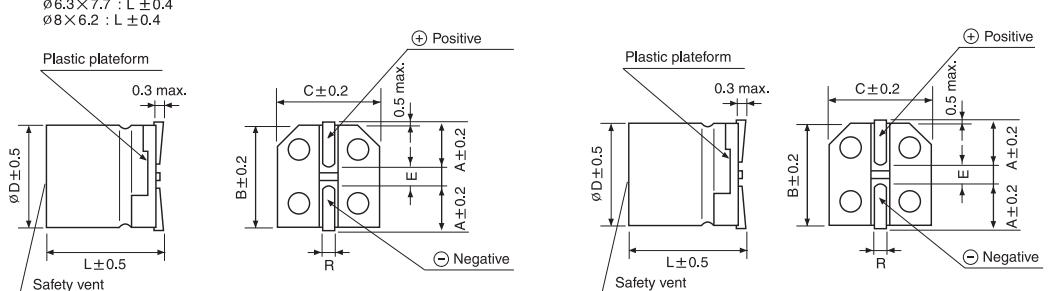
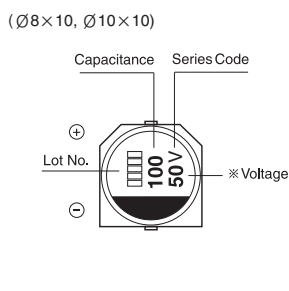
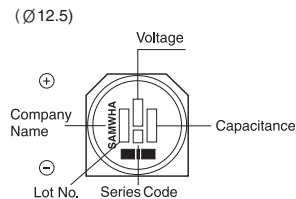
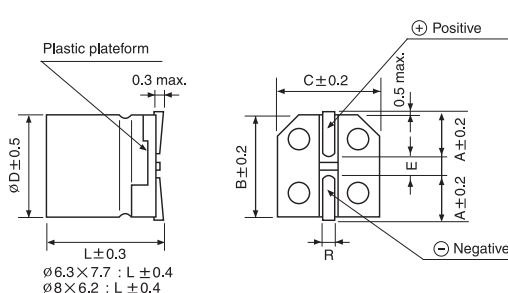
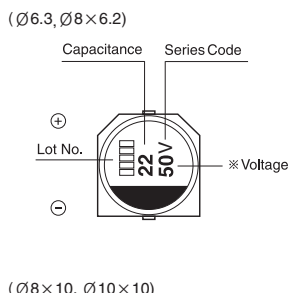

# SURFACE MOUNT ALUMINUM ELECTROLYTIC CAPACITORS

**SC** series

● DIMENSIONS & MAXIMUM PERMISSIBLE RIPPLE CURRENT

$\mu\text{F}$ \diagdown WV	4		6.3		10		16		25		35		50	
0.1													4×5.3	3.2
0.22													4×5.3	4.7
0.33													4×5.3	5.7
0.47													4×5.3	6.8
1.0													4×5.3	10
2.2											4×5.3	11	4×5.3	15
3.3									4×5.3	15	4×5.3	16	4×5.3	18
4.7							4×5.3	16	4×5.3	18	4×5.3	19	4×5.3	24
													5×5.3	25
10	4×5.3	16	4×5.3	19	4×5.3	21	4×5.3	21	4×5.3	24	4×5.3	27	5×5.3	41
									5×5.3	30	5×5.3	32	6.3×5.3	43
22	3×5.3	19	4×5.3	29	4×5.3	28	4×5.3	30	5×5.3	41	6.3×5.3	55	6.3×5.3	71
	4×5.3	24			5×5.3	36	5×5.3	41	6.3×5.3	53			6.3×5.8	73
33	4×5.3	29	4×5.3	30	4×5.3	34	5×5.3	43	5×5.3	50	6.3×5.3	65	6.3×7.7	94
			5×5.3	41	5×5.3	44	6.3×5.3	58	6.3×5.3	64	6.3×5.8	67	8×6.2	95
47	4×5.3	35	4×5.3	36	5×5.3	47	5×5.3	52	6.3×5.3	70	6.3×7.7	94	6.3×7.7	105
			5×5.3	48	6.3×5.3	62	6.3×5.3	69	6.3×5.8	72	8×6.2	105	8×10	140
100	5×5.3	54	5×5.3	60	6.3×5.3	80	6.3×5.3	88			6.3×7.7	132	8×10	181
	6.3×5.3	68	6.3×5.3	82	6.3×5.8	82	6.3×5.8	91	8×6.2	145	8×10	175	10×10	195
220	6.3×5.3	93	6.3×5.8	91	6.3×7.7	173	6.3×7.7	162	8×10	232				
					8×6.2	175	8×10	215	10×10	250	10×10	265	10×10	320
330			6.3×7.7	188										
			8×6.2	190	8×10	240	8×10	270	10×10	305	10×10	360	12.5×13.5	600
470			8×10	265	8×10	290	8×10	307						
							10×10	330	10×10	400	12.5×13.5	600		
1000			8×10	370										
			10×10	400	10×10	454	12.5×13.5	710	12.5×13.5	820				
1500			10×10	480	12.5×13.5	850	12.5×13.5	870						
2200			12.5×13.5	890	12.5×13.5	960								

Ripple current (mA rms) at 85°C, 120Hz  
 Case size  $\varnothing D \times L$  (mm)

## SC series

### ● DIMENSIONS & MAXIMUM PERMISSIBLE RIPPLE CURRENT

$\mu\text{F}$ \diagdown WV	63		100		160		200		250		400		450	
2.2													10×10	85
3.3			6.5×5.8	29							10×10	90	10×10	100
4.7	6.3×5.8	31	6.3×5.8 8×6.2	35 40			10×10	100	10×10	100	12.5×13.5	115	12.5×13.5	115
10	6.3×5.8	46	8×10	77	10×10	100	12.5×13.5	150	12.5×13.5	150				
22	8×6.2	96	8×10	100	12.5×13.5	240	12.5×13.5	260						
33	8×10	117	10×10	130	12.5×13.5	260								
47	10×10	140	10×10	155										
68	10×10	160	12.5×13.5	350										
100	12.5×13.5	370	12.5×13.5	420										
220	12.5×13.5	550												

### ● FREQUENCY COEFFICIENT OF PERMISSIBLE RIPPLE CURRENT

Frequency	50Hz	120Hz	300Hz	1kHz	10kHz $\leq$
Coefficient	0.70	1.00	1.17	1.36	1.50

# SURFACE MOUNT ALUMINUM ELECTROLYTIC CAPACITORS

**RC** Chip type, Wide Temperature Range Series

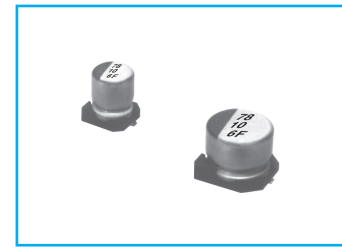

- Wide operating temperature range of -55 ~ +105°C
- Designed for surface mounting on high density PC board
- Applicable to automatic insertion machine using carrier tape
- Complied to the RoHS directive

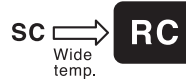

Item	Characteristics						
Operating temperature range	-55 ~ +105°C						
Leakage current max.	I = 0.01CV or 3μA whichever is greater (after 2 minutes)						
Capacitance tolerance	±20% at 120Hz, 20°C						
Dissipation factor max. (at 120Hz, 20°C)	WV	6.3	10	16	25	35	50
	tanδ	0.27	0.23	0.19	0.15	0.13	0.11
Low temperature characteristics (Impedance ratio at 120Hz)	WV	6.3	10	16	25	35	50
	Z-25°C/Z+20°C	3	3	2	2	2	2
	Z-40°C/Z+20°C	8	5	4	3	3	3
Load life (after application of the rated voltage for 1000 hours at 105°C)	Leakage current	Less than specified value					
	Capacitance change	Within ±25% of initial value					
	tanδ	Less than 200% of specified value					
Shelf life (at 105°C)	After 1000 hours no load test, leakage current, capacitance and tanδ are same as load life value. The measurement shall be performed at 20°C by the KS C 6503 clause 5.1.						
Resistance to soldering heat	The following specifications shall be satisfied when the capacitors are restored to 20°C after exposing them at 250°C for 30 seconds.						
	Leakage current	Less than specified value					
	Capacitance change	Within ±10% of initial value					
	tanδ	Less than specified value					

● DRAWING (See page 53)

Unit : mm

-Series code of RC is "F"

● DIMENSIONS & MAXIMUM PERMISSIBLE RIPPLE CURRENT

μF \ WV	6.3	10	16	25	35	50
0.1						4×5.3 2.3
0.22						4×5.3 3.4
0.33						4×5.3 4.1
0.47						4×5.3 4.9
1.0						4×5.3 7.2
2.2						4×5.3 10.7
3.3						4×5.3 13.1
4.7				4×5.3 13	4×5.3 14	5×5.3 18.1
10			4×5.3 17	5×5.3 23	5×5.3 24	6.3×5.3 30.8
22	4×5.3 22	5×5.3 27	5×5.3 30	6.3×5.3 39	6.3×5.3 42	6.3×5.8 45
33	5×5.3 31	5×5.3 33	6.3×5.3 43	6.3×5.3 48	6.3×5.8 52	6.3×7.7 60
47	5×5.3 36	6.3×5.3 46	6.3×5.3 51	6.3×5.8 59	6.3×5.8 63	6.3×7.7 63
100	6.3×5.3 50	6.3×5.8 64	6.3×5.8 64	6.3×7.7 91	8×10 296	10×10 295
220	6.3×7.7 86	6.3×7.7 105	6.3×7.7 105	8×10 340	10×10 435	
330	6.3×7.7 105	8×10 305	8×10 340	10×10 360		
470	8×10 330	10×10 340	10×10 470			
1000	10×10 475					

↑ ↑ Ripple current (mA rms) at 105°C, 120Hz  
Case size ØD×L (mm)

● FREQUENCY COEFFICIENT OF PERMISSIBLE RIPPLE CURRENT

Frequency	50Hz	120Hz	300Hz	1kHz	10kHz≤
Coefficient	0.70	1.00	1.17	1.36	1.50



# SURFACE MOUNT ALUMINUM ELECTROLYTIC CAPACITORS



**NEW**  
**UC**

Chip type, High Reliability Series



- Chip type, high temperature range, for +125°C use
- Designed for surface mounting on high density PC board
- Applicable to automatic insertion machine using carrier tape
- Complied to the RoHS directive

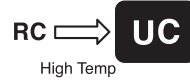

Item	Characteristics					
Operating temperature range	-40 ~ 125°C					
Leakage current max.	I = 0.01CV or 4μA whichever is greater (after 2 minutes)					
Capacitance tolerance	±20% at 120Hz, 20°C					
Dissipation factor max. (at 120Hz, 20°C)	WV	10	16	25	35	50
	tanδ	0.32	0.24	0.21	0.18	0.18
Low temperature characteristics (Impedance ratio at 120Hz)	WV	10	16	25	35	50
	Z-40°C/Z+20°C	12	8	6	4	4
Load life (after application of the rated voltage for 2000 hours at 125°C)	Leakage current	Less than specified value				
	Capacitance change	Within ±30% of initial value				
	tanδ	Less than 300% of specified value				
Shelf life (at 105°C)	After 1000 hours no load test, leakage current, capacitance and tanδ are same as load life value. The measurement shall be performed at 20°C by the KS C 6503 clause 5.1.					
Resistance to soldering heat	The following specifications shall be satisfied when the capacitors are restored to 20°C after exposing them at 250°C for 30 seconds.					
	Leakage current	Less than specified value				
	Capacitance change	Within ±10% of initial value				
	tanδ	Less than specified value				

● DRAWING (See page 59)

Unit : mm

-Series code of UC is "U"

● DIMENSIONS & MAXIMUM PERMISSIBLE RIPPLE CURRENT

μF \ WV	10		16		25		35		50	
10									8×6.2	65
22									8×6.2	65
33							8×6.2	65	8×10	125
47					8×6.2	65	8×10	125	10×10	200
68			8×6.2	65	8×6.2	65	10×10	200	12.5×13.5	525
100	8×6.2	65	8×10	125	8×10	125	10×10	200	12.5×13.5	525
220	8×10	125	10×10	200	10×10	200	12.5×13.5	525		
330	10×10	200	10×10	200	12.5×13.5	525				
470	10×10	200	12.5×13.5	525						
1000	12.5×13.5	525								

Ripple current (mA rms) at 125°C  
Case size ØD×L(mm)

● FREQUENCY COEFFICIENT OF PERMISSIBLE RIPPLE CURRENT

Frequency	50Hz	120Hz	300Hz	1kHz	10kHz ≤
Coefficient	0.70	1.00	1.17	1.36	1.50

CHIP TYPES

# SURFACE MOUNT ALUMINUM ELECTROLYTIC CAPACITORS

**CB** Chip type, Long Life Series



- Chip type with load life 5000 hours at 105°C
- Chip type with 5.5mmL Height
- Designed for surface mounting on high density PC board
- Applicable to automatic insertion machine using carrier tape
- Complied to the RoHS directive

Item	Characteristics																		
Operating temperature range	-55 ~ +105°C																		
Leakage current max.	I = 0.01CV or 3μA whichever is greater (after 2 minutes)																		
Capacitance tolerance	±20% at 120Hz, 20°C																		
Dissipation factor max. (at 120Hz, 20°C)	<table border="1"> <tr> <td>WV</td> <td>4</td> <td>6.3</td> <td>10</td> <td>16</td> <td>25</td> <td>35</td> <td>50</td> </tr> <tr> <td>tanδ</td> <td>0.24</td> <td>0.22</td> <td>0.19</td> <td>0.16</td> <td>0.14</td> <td>0.12</td> <td>0.11</td> </tr> </table>	WV	4	6.3	10	16	25	35	50	tanδ	0.24	0.22	0.19	0.16	0.14	0.12	0.11		
	WV	4	6.3	10	16	25	35	50											
tanδ	0.24	0.22	0.19	0.16	0.14	0.12	0.11												
Low temperature characteristics (Impedance ratio at 120Hz)	<table border="1"> <tr> <td>WV</td> <td>4</td> <td>6.3</td> <td>10</td> <td>16</td> <td>25 ~ 50</td> </tr> <tr> <td>Z-25°C/Z+20°C</td> <td>2</td> <td>2</td> <td>2</td> <td>2</td> <td>3</td> </tr> <tr> <td>Z-55°C/Z+20°C</td> <td>4</td> <td>4</td> <td>4</td> <td>3</td> <td>3</td> </tr> </table>	WV	4	6.3	10	16	25 ~ 50	Z-25°C/Z+20°C	2	2	2	2	3	Z-55°C/Z+20°C	4	4	4	3	3
	WV	4	6.3	10	16	25 ~ 50													
	Z-25°C/Z+20°C	2	2	2	2	3													
Z-55°C/Z+20°C	4	4	4	3	3														
Load life (after application of the rated voltage for 5000 hours at 105°C)	Capacitance change	Within ±30% of initial value																	
	tanδ	Less than 300% of the specified value																	
	Leakage current	Less than specified value																	
Shelf life (at 105°C)	After 1000 hours no load test, leakage current, capacitance and tanδ are same as load life value. The measurement shall be performed at 20°C by the KS C 6503 clause 5.1.																		
Resistance to soldering heat	The following specifications shall be satisfied when the capacitors are restored to 20°C after exposing them at 250°C for 30 seconds.																		
	Leakage current	Less than specified value																	
	Capacitance change	Within ±10% of initial value																	
	tanδ	Less than specified value																	

● DRAWING (See page 53)

Unit : mm

-Series code of CB is "B"

● DIMENSIONS & MAXIMUM PERMISSIBLE RIPPLE CURRENT

μF \ WV	4	6.3	10	16	25	35	50
0.1							4×5.3 2.4
0.22							4×5.3 3.5
0.33							4×5.3 4.3
0.47							4×5.3 5.1
1.0							4×5.3 7.4
2.2							4×5.3 11.0
3.3							4×5.3 13.5
4.7					4×5.3 14	4×5.3 15	5×5.3 18.6
6.8					4×5.3 17	5×5.3 21	6.3×5.3 26.1
10				4×5.3 19	5×5.3 24	5×5.3 26	6.3×5.3 32.6
15			4×5.3 22	5×5.3 28	5×5.3 31	6.3×5.3 37	6.3×5.3 40.0
22	4×5.3 24	4×5.3 25	5×5.3 30	5×5.3 33	6.3×5.3 42	6.3×5.3 45	
33	5×5.3 33	5×5.3 35	5×5.3 38	6.3×5.3 48			
47	5×5.3 40	5×5.3 42	6.3×5.3 52	6.3×5.3 57			
68	5×5.3 48	6.3×5.3 55	6.3×5.3 63				
100	5×5.3 55	6.3×5.3 67	6.3×5.3 72				

↑  
Ripple current (mA rms) at 105°C, 120Hz  
Case size ØD×L(mm)

● FREQUENCY COEFFICIENT OF PERMISSIBLE RIPPLE CURRENT

Frequency	50Hz	120Hz	300Hz	1kHz	10kHz≤
Coefficient	0.70	1.00	1.17	1.36	1.50

## JC Chip type, Higher Capacitance Range Series

- Chip type higher capacitance in large case sizes
- Designed for surface mounting on high density PC board
- Applicable to automatic insertion machine using carrier tape
- Complied to the RoHS directive

**S**  
Solvent Proof  
WV ≤ 100V

RC → **JC**  
Long life

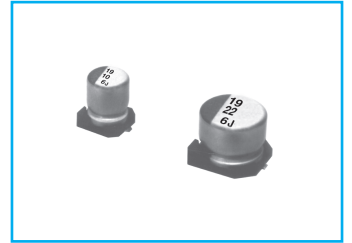

Item	Characteristics																														
<b>Operating temperature range</b>	WV ≤ 100 : -55 ~ +105°C    WV ≥ 160 : -40 ~ +105°C																														
<b>Leakage current max.</b>	WV ≤ 100 I = 0.01CV or 3μA whichever is greater (after 2 minutes) WV ≥ 160 I = 0.04CV + 100μA (after 1 minutes)																														
<b>Capacitance tolerance</b>	±20% at 120Hz, 20°C																														
<b>Dissipation factor max. (at 120Hz, 20°C)</b>	<table border="1"> <tr> <td>WV</td> <td>4</td> <td>6.3</td> <td>10</td> <td>16</td> <td>25</td> <td>35</td> <td>50</td> <td>63</td> <td>100</td> <td>160</td> <td>200</td> <td>250</td> <td>400</td> <td>450</td> </tr> <tr> <td>tanδ</td> <td>0.37</td> <td>0.28</td> <td>0.24</td> <td>0.20</td> <td>0.16</td> <td>0.13</td> <td>0.12</td> <td>0.10</td> <td>0.10</td> <td>0.15</td> <td>0.15</td> <td>0.15</td> <td>0.20</td> <td>0.20</td> </tr> </table>	WV	4	6.3	10	16	25	35	50	63	100	160	200	250	400	450	tanδ	0.37	0.28	0.24	0.20	0.16	0.13	0.12	0.10	0.10	0.15	0.15	0.15	0.20	0.20
WV	4	6.3	10	16	25	35	50	63	100	160	200	250	400	450																	
tanδ	0.37	0.28	0.24	0.20	0.16	0.13	0.12	0.10	0.10	0.15	0.15	0.15	0.20	0.20																	
<b>Low temperature characteristics (Impedance ratio at 120Hz)</b>	<table border="1"> <tr> <td>WV</td> <td>4</td> <td>6.3</td> <td>10</td> <td>16</td> <td>25 ~ 50</td> <td>63 ~ 100</td> <td>160 ~ 250</td> <td>400 ~ 450</td> </tr> <tr> <td>Z-25°C/Z+20°C</td> <td>6</td> <td>3</td> <td>3</td> <td>2</td> <td>2</td> <td>3</td> <td>3</td> <td>6</td> </tr> <tr> <td>Z-40°C/Z+20°C</td> <td>12</td> <td>8</td> <td>5</td> <td>4</td> <td>3</td> <td>4</td> <td>6</td> <td>10</td> </tr> </table>	WV	4	6.3	10	16	25 ~ 50	63 ~ 100	160 ~ 250	400 ~ 450	Z-25°C/Z+20°C	6	3	3	2	2	3	3	6	Z-40°C/Z+20°C	12	8	5	4	3	4	6	10			
WV	4	6.3	10	16	25 ~ 50	63 ~ 100	160 ~ 250	400 ~ 450																							
Z-25°C/Z+20°C	6	3	3	2	2	3	3	6																							
Z-40°C/Z+20°C	12	8	5	4	3	4	6	10																							
<b>Load life (after application of the rated voltage for 2000 hours at 105°C)</b>	<table border="1"> <tr> <td>Leakage current</td> <td>Less than specified value</td> </tr> <tr> <td>Capacitance change</td> <td>Within ±20% of initial value (Small size : ±25%)</td> </tr> <tr> <td>tanδ</td> <td>Less than 200% of specified value</td> </tr> </table>	Leakage current	Less than specified value	Capacitance change	Within ±20% of initial value (Small size : ±25%)	tanδ	Less than 200% of specified value																								
Leakage current	Less than specified value																														
Capacitance change	Within ±20% of initial value (Small size : ±25%)																														
tanδ	Less than 200% of specified value																														
<b>Shelf life (at 105°C)</b>	After 1000 hours no load test, leakage current, capacitance and tanδ are same as load life value. The measurement shall be performed at 20°C by the KS C 6503 clause 5.1.																														
<b>Resistance to soldering heat</b>	<p>The following specifications shall be satisfied when the capacitors are restored to 20°C after exposing them at 250°C for 30 seconds.</p> <table border="1"> <tr> <td>Leakage current</td> <td>Less than specified value</td> </tr> <tr> <td>Capacitance change</td> <td>Within ±10% of initial value</td> </tr> <tr> <td>tanδ</td> <td>Less than specified value</td> </tr> </table>	Leakage current	Less than specified value	Capacitance change	Within ±10% of initial value	tanδ	Less than specified value																								
Leakage current	Less than specified value																														
Capacitance change	Within ±10% of initial value																														
tanδ	Less than specified value																														

### ● DRAWING -Series code of JC is "J"

Unit : mm

(∅6.3, ∅8×6.2)

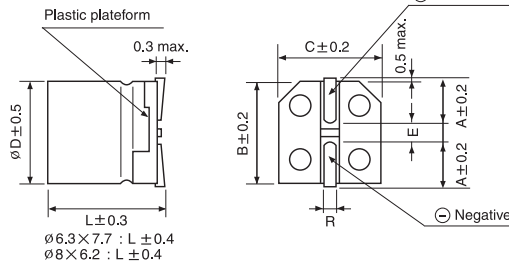
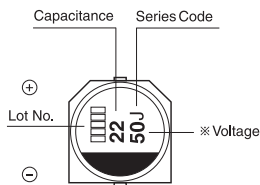

∅D×L	A	B	C	E	R
6.3×5.8	2.4	6.6	6.6	2.2	0.5~0.8
6.3×7.7	2.4	6.6	6.6	2.2	0.5~0.8
8×6.2	3.3	8.3	8.3	2.3	0.5~0.8
8×10	2.9	8.3	8.3	3.1	0.8~1.1
10×10	3.2	10.3	10.3	4.5	0.8~1.1
12.5×13.5	4.6	12.8	12.8	4.5	0.8~1.4

(∅8×10, ∅10×10)

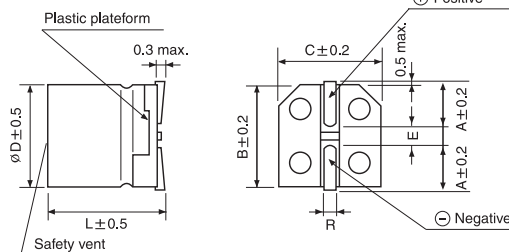
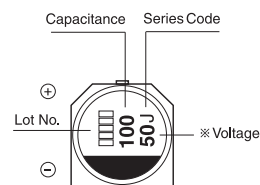

(∅12.5)

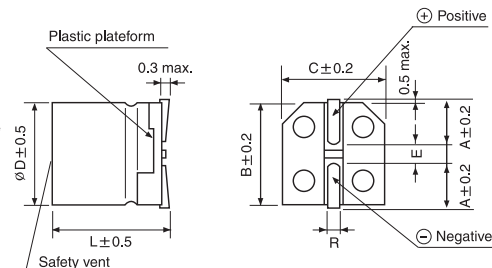
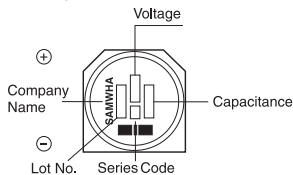

# SURFACE MOUNT ALUMINUM ELECTROLYTIC CAPACITORS

**JC** series

● DIMENSIONS & MAXIMUM PERMISSIBLE RIPPLE CURRENT

$\mu\text{F}$ \diagdown WV	4		6.3		10		16		25		35		50	
10													6.3×5.8	30
22									6.3×5.8	38	6.3×5.8	42	8×6.2	67
33							6.3×5.8	40	6.3×5.8	48	8×6.2	76	8×10	133
47					6.3×5.8	46	6.3×5.8	50	8×6.2	79	8×10	124	10×10	180
100	6.3×5.8	60	6.3×5.8	60	6.3×5.8	60	8×10	148	8×10	181	10×10	304	10×10	310
220			8×10	161	8×10	173	10×10	330	10×10	351	10×10	450	12.5×13.5	480
330			8×10	288	10×10	318	10×10	441	10×10	372	12.5×13.5	500		
470			10×10	340	10×10	351	10×10	489	10×10	450	12.5×13.5	600		
680			10×10	408	10×10	392	12.5×13.5	500	12.5×13.5	500				
1000			10×10	495	10×10	550	12.5×13.5	600						
1500			10×10	560	12.5×13.5	650								
2200			12.5×13.5	730										

$\mu\text{F}$ \diagdown WV	63		100		160		200		250		400		450		
3.3									10×10	30	12.5×13.5	30	12.5×13.5	40	
4.7							10×10	45	12.5×13.5	65					
10	8×6.2	32			10×10	45	12.5×13.5	75							
22	8×10	60	8×10	90	12.5×13.5	85	12.5×13.5	85							
33	8×10	110	10×10	120	12.5×13.5	95	← Ripple current (mA rms) at 105°C, 120Hz								
47	10×10	130	12.5×13.5	250	↑ Case size $\varnothing D \times L$ (mm)										
68	10×10	160	12.5×13.5	300											
100	12.5×13.5	270													

● FREQUENCY COEFFICIENT OF PERMISSIBLE RIPPLE CURRENT

Frequency	50Hz	120Hz	300Hz	1kHz	10kHz $\leq$
Coefficient	0.70	1.00	1.17	1.36	1.50

# SURFACE MOUNT ALUMINUM ELECTROLYTIC CAPACITORS



**NEW**  
**JH**

Chip type, High Ripple Current Series



- High Ripple current Compared with JC sizes
- Designed for surface mounting on high density PC board
- Applicable to automatic insertion machine using carrier tape
- Complied to the RoHS directive

JC → **JH**  
High Ripple

Item	Characteristics																		
Operating temperature range	-55 ~ +105°C																		
Leakage current max.	$I = 0.01CV$ or $3\mu A$ whichever is greater (after 2 minutes)																		
Capacitance tolerance	$\pm 20\%$ at 120Hz, 20°C																		
Dissipation factor max. (at 120Hz, 20°C)	<table border="1"> <tr> <td>WV</td> <td>6.3</td> <td>10</td> <td>16</td> <td>25</td> <td>35</td> <td>50</td> <td>63</td> <td>100</td> </tr> <tr> <td><math>\tan\delta</math></td> <td>0.28</td> <td>0.24</td> <td>0.20</td> <td>0.16</td> <td>0.13</td> <td>0.12</td> <td>0.10</td> <td>0.10</td> </tr> </table>	WV	6.3	10	16	25	35	50	63	100	$\tan\delta$	0.28	0.24	0.20	0.16	0.13	0.12	0.10	0.10
WV	6.3	10	16	25	35	50	63	100											
$\tan\delta$	0.28	0.24	0.20	0.16	0.13	0.12	0.10	0.10											
Low temperature characteristics (Impedance ratio at 120Hz)	<table border="1"> <tr> <td>WV</td> <td>6.3</td> <td>10</td> <td>16</td> <td>25 ~ 50</td> <td>63 ~ 100</td> </tr> <tr> <td>Z-25°C/Z+20°C</td> <td>3</td> <td>3</td> <td>2</td> <td>2</td> <td>3</td> </tr> <tr> <td>Z-55°C/Z+20°C</td> <td>8</td> <td>5</td> <td>4</td> <td>3</td> <td>4</td> </tr> </table>	WV	6.3	10	16	25 ~ 50	63 ~ 100	Z-25°C/Z+20°C	3	3	2	2	3	Z-55°C/Z+20°C	8	5	4	3	4
WV	6.3	10	16	25 ~ 50	63 ~ 100														
Z-25°C/Z+20°C	3	3	2	2	3														
Z-55°C/Z+20°C	8	5	4	3	4														
Load life (after application of the rated voltage for 2000 hours at 105°C)	<table border="1"> <tr> <td>Leakage current</td> <td>Less than specified value</td> </tr> <tr> <td>Capacitance change</td> <td>Within <math>\pm 20\%</math> of initial value</td> </tr> <tr> <td><math>\tan\delta</math></td> <td>Less than 200% of specified value</td> </tr> </table>	Leakage current	Less than specified value	Capacitance change	Within $\pm 20\%$ of initial value	$\tan\delta$	Less than 200% of specified value												
Leakage current	Less than specified value																		
Capacitance change	Within $\pm 20\%$ of initial value																		
$\tan\delta$	Less than 200% of specified value																		
Shelf life (at 105°C)	After 1000 hours no load test, leakage current, capacitance and $\tan\delta$ are same as load life value. The measurement shall be performed at 20°C by the KS C 6503 clause 5.1.																		
Resistance to soldering heat	<p>The following specifications shall be satisfied when the capacitors are restored to 20°C after exposing them at 250°C for 30 seconds.</p> <table border="1"> <tr> <td>Leakage current</td> <td>Less than specified value</td> </tr> <tr> <td>Capacitance change</td> <td>Within <math>\pm 10\%</math> of initial value</td> </tr> <tr> <td><math>\tan\delta</math></td> <td>Less than specified value</td> </tr> </table>	Leakage current	Less than specified value	Capacitance change	Within $\pm 10\%$ of initial value	$\tan\delta$	Less than specified value												
Leakage current	Less than specified value																		
Capacitance change	Within $\pm 10\%$ of initial value																		
$\tan\delta$	Less than specified value																		

## ● DRAWING -Series code of JH is "G"

Unit : mm

( $\phi 6.3, \phi 8 \times 6.2$ )

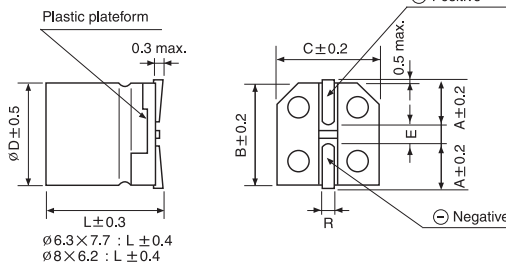
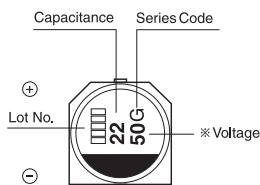

$\phi D \times L$	A	B	C	E	R
6.3 × 5.8	2.4	6.6	6.6	2.2	0.5~0.8
6.3 × 7.7	2.4	6.6	6.6	2.2	0.5~0.8
8 × 6.2	3.3	8.3	8.3	2.3	0.5~0.8
8 × 10	2.9	8.3	8.3	3.1	0.8~1.1
10 × 10	3.2	10.3	10.3	4.5	0.8~1.1
12.5 × 13.5	4.6	12.8	12.8	4.5	0.8~1.4

( $\phi 8 \times 10, \phi 10 \times 10$ )

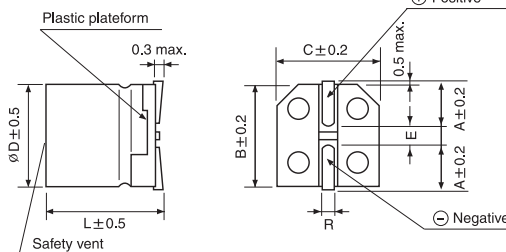
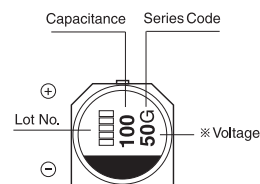

( $\phi 12.5$ )

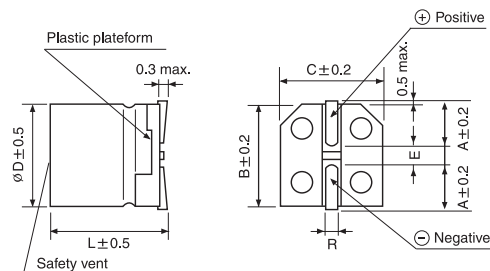
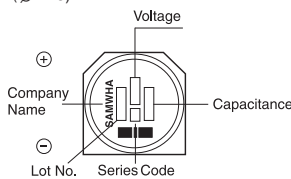

# SURFACE MOUNT ALUMINUM ELECTROLYTIC CAPACITORS

**JH** series

● DIMENSIONS & MAXIMUM PERMISSIBLE RIPPLE CURRENT

$\mu\text{F}$ \diagdown WV	6.3		10		16		25		35	
10										
22							6.3×5.8	57	6.3×5.8	63
33					6.3×5.8	60	6.3×5.8	72	8×6.2	114
47			6.3×5.8	69	6.3×5.8	75	8×6.2	118.5	8×10	186
100	6.3×5.8	90	6.3×5.8	90	8×10	222	8×10	271.5	10×10	456
220	8×10	241.5	8×10	259.5	10×10	495	10×10	526.5	10×10	675
330	8×10	432	10×10	477	10×10	661.5	10×10	558	12.5×13.5	750
470	10×10	510	10×10	526.5	10×10	733.5	10×10	675	12.5×13.5	900
680	10×10	612	10×10	588	12.5×13.5	750	12.5×13.5	750		
1000	10×10	742.5	10×10	825	12.5×13.5	900				
1500	10×10	840	12.5×13.5	975						
2200	12.5×13.5	1095								

↑ Ripple current (mA rms) at 105°C, 120Hz  
 ↑ Case size  $\varnothing D \times L$  (mm)

$\mu\text{F}$ \diagdown WV	50		63		100	
10	6.3×5.8	45	8×6.2	48		
22	8×6.2	100.5	8×10	90	8×10	135
33	8×10	199.5	8×10	165	10×10	180
47	10×10	270	10×10	195	12.5×13.5	375
68	10×10	315	10×10	240	12.5×13.5	450
100	10×10	465	12.5×13.5	405		
220	12.5×13.5	720				

● FREQUENCY COEFFICIENT OF PERMISSIBLE RIPPLE CURRENT

Frequency	50Hz	120Hz	300Hz	1kHz	10kHz $\leq$
Coefficient	0.70	1.00	1.17	1.36	1.50

## ZC Height 5.5mmL, Low Impedance Series

**LI** Low Impedance      **S** Solvent Proof



- Chip type, low impedance temperature range up to 105°C
- Designed for surface mounting on high density PC board
- Applicable to automatic insertion machine using carrier tape
- Complied to the RoHS directive

RC → **ZC**  
Low Imp.

Item	Characteristics					
Operating temperature range	-55 ~ +105°C					
Leakage current max.	I = 0.01CV or 3μA whichever is greater (after 2 minutes)					
Capacitance tolerance	±20% at 120Hz, 20°C					
Dissipation factor max. (at 120Hz, 20°C)	WV	6.3	10	16	25	35
	tanδ	0.22	0.19	0.16	0.14	0.12
Low temperature characteristics (Impedance ratio at 120Hz)	WV	6.3	10	16	25	35
	Z-25°C/Z+20°C	2	2	2	2	3
	Z-55°C/Z+20°C	4	4	3	3	3
Load life (after application of the rated voltage for 1000 hours at 105°C)	Leakage current	Less than specified value				
	Capacitance change	Within ±20% of initial value				
	tanδ	Less than 200% of specified value				
Shelf life (at 105°C)	After 1000 hours no load test, leakage current, capacitance and tanδ are same as load life value. The measurement shall be performed at 20°C by the KS C 6503 clause 5.1.					
Resistance to soldering heat	The following specifications shall be satisfied when the capacitors are restored to 20°C after exposing them at 250°C for 30 seconds.					
	Leakage current	Less than specified value				
	Capacitance change	Within ±10% of initial value				
	tanδ	Less than specified value				

### ● DRAWING -Series code of ZC is "Z"

Unit : mm

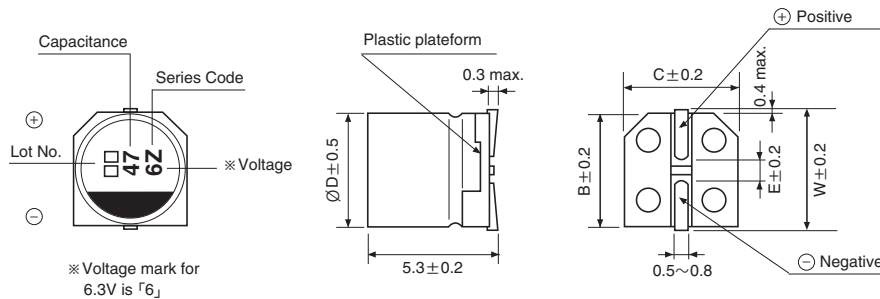

ØD	W	B	C	E
4	4.8	4.3	4.3	1.0
5	5.8	5.3	5.3	1.4
6.3	7.1	6.6	6.6	2.2

### ● DIMENSIONS & MAXIMUM PERMISSIBLE RIPPLE CURRENT

μF \ WV	6.3			10			16			25			35			
1.0													4×5.3	5.0	50	
1.5													4×5.3	5.0	50	
2.2													4×5.3	5.0	50	
3.3													4×5.3	5.0	50	
4.7										4×5.3	5.0	50	4×5.3	5.0	50	
6.8										4×5.3	5.0	50	5×5.3	2.6	80	
10								4×5.3	5.0	50	5×5.3	2.6	80	5×5.3	2.6	80
15								5×5.3	2.6	80	6.3×5.3	1.3	75	6.3×5.3	1.3	115
22	4×5.3	5.0	50	5×5.3	2.6	80	5×5.3	2.6	80	6.3×5.3	1.3	115	6.3×5.3	1.3	115	
33	5×5.3	2.6	80	5×5.3	2.6	80	6.3×5.3	1.3	115	6.3×5.3	1.3	115	6.3×5.3	1.3	115	
47	5×5.3	2.6	80	6.3×5.3	1.3	115	6.3×5.3	1.3	115	6.3×5.3	1.3	115	6.3×5.3	1.3	115	
68	6.3×5.3	1.3	115	6.3×5.3	1.3	115	6.3×5.3	1.3	115	6.3×5.3	1.3	115	6.3×5.3	1.3	115	
100	6.3×5.3	1.3	115	6.3×5.3	1.3	115	6.3×5.3	1.3	115	6.3×5.3	1.3	115	6.3×5.3	1.3	115	

← Ripple current (mA rms) at 105°C, 100kHz  
 ↑ Impedance (Ω) at 20°C, 100kHz  
 Case size ØD×L(mm)

### ● FREQUENCY COEFFICIENT OF PERMISSIBLE RIPPLE CURRENT

Frequency	50Hz	120Hz	300Hz	1kHz	10kHz ≤
Coefficient	0.35	0.5	0.64	0.83	1.00

# SURFACE MOUNT ALUMINUM ELECTROLYTIC CAPACITORS

**CK** Chip type, Low Impedance, High CV Series

**IZI** Low Impedance **S** Solvent Proof

- Chip type, low impedance temperature range up to 105°C
- Designed for surface mounting on high density PC board
- Applicable to automatic insertion machine using carrier tape
- Complied to the RoHS directive

ZC → **CK**  
Low Imp.



Item	Characteristics																								
Operating temperature range	-55 ~ +105°C																								
Leakage current max.	I = 0.01CV or 3μA whichever is greater (after 2 minutes)																								
Capacitance tolerance	±20% at 120Hz, 20°C																								
Dissipation factor max. (at 120Hz, 20°C)	<table border="1"> <tr> <td>WV</td> <td>6.3</td> <td>10</td> <td>16</td> <td>25</td> <td>35</td> <td>50</td> <td>63</td> <td>80</td> <td>100</td> </tr> <tr> <td>tanδ</td> <td>0.24</td> <td>0.19</td> <td>0.16</td> <td>0.14</td> <td>0.12</td> <td>0.12</td> <td>0.10</td> <td>0.10</td> <td>0.10</td> </tr> </table>	WV	6.3	10	16	25	35	50	63	80	100	tanδ	0.24	0.19	0.16	0.14	0.12	0.12	0.10	0.10	0.10				
WV	6.3	10	16	25	35	50	63	80	100																
tanδ	0.24	0.19	0.16	0.14	0.12	0.12	0.10	0.10	0.10																
Low temperature characteristics (Impedance ratio at 120Hz)	<table border="1"> <tr> <td>WV</td> <td>6.3</td> <td>10</td> <td>16</td> <td>25</td> <td>35</td> <td>50</td> <td>63~100</td> </tr> <tr> <td>Z-25°C/Z+20°C</td> <td>2</td> <td>2</td> <td>2</td> <td>2</td> <td>2</td> <td>2</td> <td>3</td> </tr> <tr> <td>Z-55°C/Z+20°C</td> <td>3</td> <td>3</td> <td>3</td> <td>3</td> <td>3</td> <td>3</td> <td>4</td> </tr> </table>	WV	6.3	10	16	25	35	50	63~100	Z-25°C/Z+20°C	2	2	2	2	2	2	3	Z-55°C/Z+20°C	3	3	3	3	3	3	4
WV	6.3	10	16	25	35	50	63~100																		
Z-25°C/Z+20°C	2	2	2	2	2	2	3																		
Z-55°C/Z+20°C	3	3	3	3	3	3	4																		
Load life (after application of the rated voltage for 2000 hours at 105°C)	<table border="1"> <tr> <td>Leakage current</td> <td>Less than specified value</td> </tr> <tr> <td>Capacitance change</td> <td>Within ±25% of initial value</td> </tr> <tr> <td>tanδ</td> <td>Less than 200% of specified value</td> </tr> </table>	Leakage current	Less than specified value	Capacitance change	Within ±25% of initial value	tanδ	Less than 200% of specified value																		
Leakage current	Less than specified value																								
Capacitance change	Within ±25% of initial value																								
tanδ	Less than 200% of specified value																								
Shelf life (at 105°C)	After 1000 hours no load test, leakage current, capacitance and tanδ are same as load life value. The measurement shall be performed at 20°C by the KS C 6503 clause 5.1.																								
Resistance to soldering heat	<p>The following specifications shall be satisfied when the capacitors are restored to 20°C after exposing them at 250°C for 30 seconds.</p> <table border="1"> <tr> <td>Leakage current</td> <td>Less than specified value</td> </tr> <tr> <td>Capacitance change</td> <td>Within ±10% of initial value</td> </tr> <tr> <td>tanδ</td> <td>Less than specified value</td> </tr> </table>	Leakage current	Less than specified value	Capacitance change	Within ±10% of initial value	tanδ	Less than specified value																		
Leakage current	Less than specified value																								
Capacitance change	Within ±10% of initial value																								
tanδ	Less than specified value																								

## ● DRAWING -Series code of CK is "K"

Unit : mm

(∅6.3, ∅8×6.2)

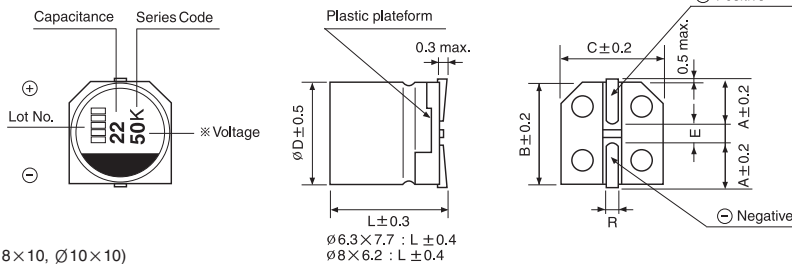

∅D×L	A	B	C	E	R
6.3×5.8	2.4	6.6	6.6	2.2	0.5~0.8
6.3×7.7	2.4	6.6	6.6	2.2	0.5~0.8
8×6.2	3.3	8.3	8.3	2.3	0.5~0.8
8×10	2.9	8.3	8.3	3.1	0.8~1.1
10×10	3.2	10.3	10.3	4.5	0.8~1.1
12.5×13.5	4.6	12.8	12.8	4.5	0.8~1.4

(∅8×10, ∅10×10)

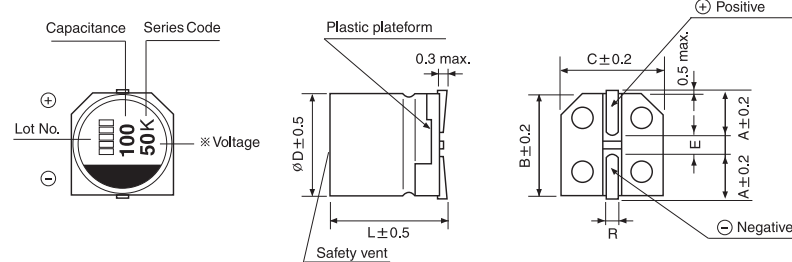

(∅12.5×13.5)

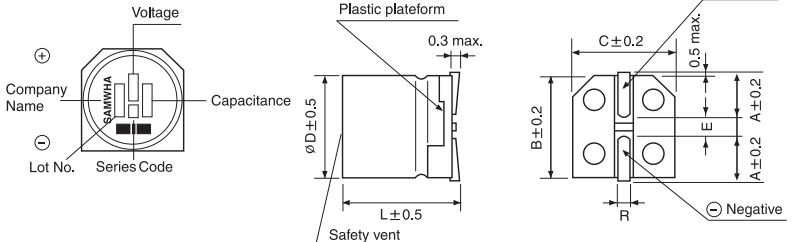



**CK** series

● DIMENSIONS & MAXIMUM PERMISSIBLE RIPPLE CURRENT

$\mu F$ \ WV	6.3			10			16			25			35			50		
10																6.3×5.8	0.88	165
15																6.3×5.8	0.88	165
22																6.3×5.8	0.88	165
33							6.3×5.8	0.44	230	6.3×5.8	0.44	230	6.3×5.8	0.44	230	6.3×7.7	0.68	280
																8×6.2	0.63	300
47				6.3×5.8	0.44	230	6.3×5.8	0.44	230	6.3×5.8	0.44	230	6.3×5.8	0.44	230	6.3×7.7	0.68	280
																8×6.2	0.63	300
68	6.3×5.8	0.44	230	6.3×5.8	0.44	230	6.3×5.8	0.44	230	6.3×5.8	0.44	230	6.3×7.7	0.34	280	8×10	0.34	450
													8×6.2	0.26	300			
100	6.3×5.8	0.44	230	6.3×5.8	0.44	230	6.3×5.8	0.44	230	6.3×7.7	0.34	280	8×10	0.17	450	10×10	0.18	670
										8×6.2	0.26	300						
150	6.3×5.8	0.44	230	6.3×5.8	0.44	230	6.3×7.7	0.34	280	8×10	0.17	450	8×10	0.17	450			
							8×6.2	0.26	300									
220	6.3×5.8	0.44	230	6.3×7.7	0.34	280	6.3×7.7	0.34	280	8×10	0.17	450	10×10	0.09	670			
				8×6.2	0.26	300	8×6.2	0.26	300									
330	6.3×7.7	0.34	280	8×10	0.17	450	8×10	0.17	450	10×10	0.09	670						
	8×6.2	0.26	300															
470	8×10	0.17	450	8×10	0.17	450	10×10	0.09	670	← Ripple current (mA rms) at 105°C, 100kHz								
680	8×10	0.17	450	10×10	0.09	670				↑ Impedance ( $\Omega$ ) at 20°C, 100kHz								
1000	10×10	0.09	670							↑ Case size $\varnothing D \times L$ (mm)								
1500	10×10	0.09	670															

$\mu F$ \ WV	63			80			100		
10	6.3×5.8	2.3	80	6.3×7.7	2.4	60			
22	6.3×7.7	2.1	120	8×10	1.3	130	8×10	1.3	130
33	8×10	0.9	250	8×10	1.3	130	10×10	0.7	200
47	8×10	0.9	250	10×10	0.7	200	12.5×13.5	0.45	500
68	10×10	0.45	400	12.5×13.5	0.45	500	12.5×13.5	0.45	500
100	10×10	0.45	400	12.5×13.5	0.45	500			
150	12.5×13.5	0.32	800	12.5×13.5	0.45	500			
220	12.5×13.5	0.32	800						

● FREQUENCY COEFFICIENT OF PERMISSIBLE RIPPLE CURRENT

Frequency	50Hz	120Hz	300Hz	1kHz	10kHz $\leq$
Coefficient	0.35	0.5	0.64	0.83	1.00

CHIP TYPES

# SURFACE MOUNT ALUMINUM ELECTROLYTIC CAPACITORS

**CD** Chip type, Extremely Low Impedance Series

**LI** Low Impedance **S** Solvent Proof

- Chip type, low impedance temperature range up to 105°C
- Designed for surface mounting on high density PC board
- Applicable to automatic insertion machine using carrier tape
- Complied to the RoHS directive

**CK** ⇌ **CD**  
Low Imp.

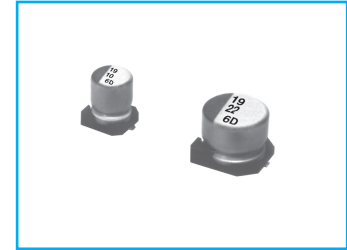

Item	Characteristics																					
Operating temperature range	-55 ~ +105°C																					
Leakage current max.	I = 0.01CV or 3μA whichever is greater (after 2 minutes)																					
Capacitance tolerance	±20% at 120Hz, 20°C																					
Dissipation factor max. (at 120Hz, 20°C)	<table border="1"> <tr> <td>WV</td> <td>6.3</td> <td>10</td> <td>16</td> <td>25</td> <td>35</td> <td>50</td> </tr> <tr> <td>tanδ</td> <td>0.24</td> <td>0.19</td> <td>0.16</td> <td>0.14</td> <td>0.12</td> <td>0.12</td> </tr> </table>	WV	6.3	10	16	25	35	50	tanδ	0.24	0.19	0.16	0.14	0.12	0.12							
	WV	6.3	10	16	25	35	50															
tanδ	0.24	0.19	0.16	0.14	0.12	0.12																
Low temperature characteristics (Impedance ratio at 120Hz)	<table border="1"> <tr> <td>WV</td> <td>6.3</td> <td>10</td> <td>16</td> <td>25</td> <td>35</td> <td>50</td> </tr> <tr> <td>Z-25°C/Z+20°C</td> <td>2</td> <td>2</td> <td>2</td> <td>2</td> <td>2</td> <td>2</td> </tr> <tr> <td>Z-55°C/Z+20°C</td> <td>3</td> <td>3</td> <td>3</td> <td>3</td> <td>3</td> <td>3</td> </tr> </table>	WV	6.3	10	16	25	35	50	Z-25°C/Z+20°C	2	2	2	2	2	2	Z-55°C/Z+20°C	3	3	3	3	3	3
WV	6.3	10	16	25	35	50																
Z-25°C/Z+20°C	2	2	2	2	2	2																
Z-55°C/Z+20°C	3	3	3	3	3	3																
Load life (after application of the rated voltage for 2000 hours at 105°C)	Leakage current	Less than specified value																				
	Capacitance change	Within ±25% of initial value																				
	tanδ	Less than 200% of specified value																				
Shelf life (at 105°C)	After 1000 hours no load test, leakage current, capacitance and tanδ are same as load life value. The measurement shall be performed at 20°C by the KS C 6503 clause 5.1.																					
Resistance to soldering heat	Leakage current	Less than specified value																				
	Capacitance change	Within ±10% of initial value																				
	tanδ	Less than specified value																				

## ● DRAWING

Unit : mm

-Series code of CD is "D"

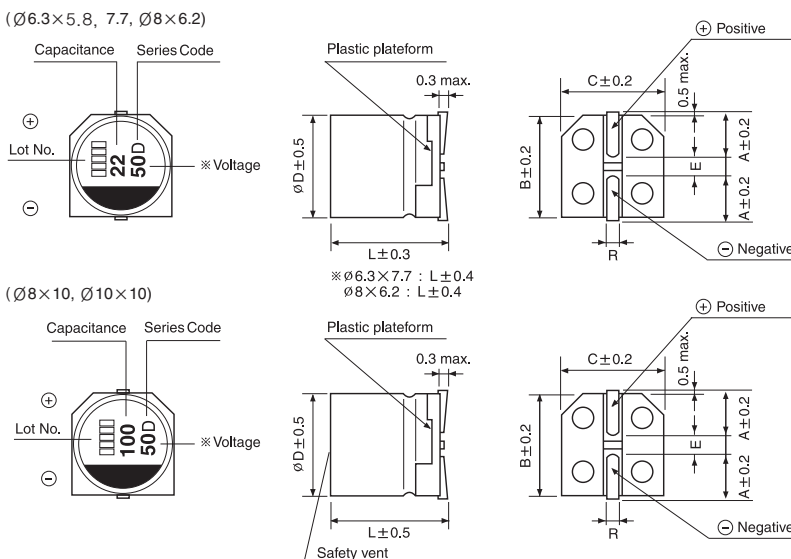

∅D	A	B	C	E	R
6.3×5.8	2.4	6.6	6.6	2.2	0.5~0.8
6.3×7.7	2.4	6.6	6.6	2.2	0.5~0.8
8×6.2	3.3	8.3	8.3	2.3	0.5~0.8
8×10	2.9	8.3	8.3	3.1	0.8~1.1
10×10	3.2	10.3	10.3	4.5	0.8~1.1

**CD** series

● **DIMENSIONS & MAXIMUM PERMISSIBLE RIPPLE CURRENT**

$\mu\text{F}$ \diagdown WV	6.3			10			16			25			35			50		
10																6.3×5.8	0.86	170
15																6.3×5.8	0.86	170
22																6.3×5.8	0.86	170
33							6.3×5.8	0.39	240	6.3×5.8	0.39	240	6.3×5.8	0.39	240	6.3×7.7	0.66	280
																8×6.2	0.63	300
47				6.3×5.8	0.39	240	6.3×5.8	0.39	240	6.3×5.8	0.39	240	6.3×5.8	0.39	240	6.3×7.7	0.66	280
																8×6.2	0.63	300
68	6.3×5.8	0.36	240	6.3×5.8	0.36	240	6.3×5.8	0.36	240	6.3×5.8	0.36	240	6.3×7.7	0.32	290	8×10	0.32	350
100	6.3×5.8	0.36	240	6.3×5.8	0.36	240	6.3×5.8	0.36	240	6.3×7.7	0.32	290	8×10	0.16	600	10×10	0.16	700
										8×6.2	0.26	300						
150	6.3×5.8	0.36	240	6.3×5.8	0.36	240	6.3×7.7	0.32	290	8×10	0.16	600	8×10	0.16	600			
220	6.3×5.8	0.36	240	6.3×7.7	0.32	290	6.3×7.7	0.32	290	8×10	0.16	600	10×10	0.08	850			
				8×6.2	0.26	300	8×6.2	0.26	300									
330	6.3×7.7	0.32	290	8×10	0.16	600	8×10	0.16	600	10×10	0.10	850						
	8×6.2	0.26	300															
470	8×10	0.16	600	8×10	0.16	600	10×10	0.08	850	← Ripple current (mA rms) at 105°C, 100kHz								
680	8×10	0.16	600	10×10	0.08	850				↑ Impedance ( $\Omega$ ) at 20°C, 100kHz								
1000	10×10	0.08	850							↑ Case size $\varnothing D \times L$ (mm)								
1500	10×10	0.08	850															

CHIP TYPES

● **FREQUENCY COEFFICIENT OF PERMISSIBLE RIPPLE CURRENT**

Frequency	50Hz	120Hz	300Hz	1kHz	10kHz $\leq$
Coefficient	0.35	0.5	0.64	0.83	1.00

# SURFACE MOUNT ALUMINUM ELECTROLYTIC CAPACITORS

**CM** Chip type, Extremely Low Impedance  
Long Life Series

**IZI** Low Impedance **S** Solvent Proof

- Chip type, low impedance temperature range up to 105°C
- Designed for surface mounting on high density PC board
- Applicable to automatic insertion machine using carrier tape
- Complied to the RoHS directive

CD → Long life **CM**

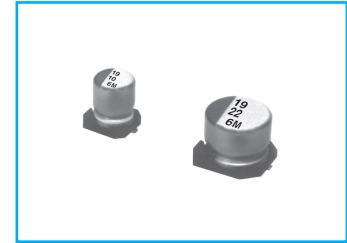

Item	Characteristics																					
Operating temperature range	-55 ~ +105°C																					
Leakage current max.	I = 0.01CV or 3μA whichever is greater (after 2 minutes)																					
Capacitance tolerance	±20% at 120Hz, 20°C																					
Dissipation factor max. (at 120Hz, 20°C)	<table border="1"> <tr> <td>WV</td> <td>6.3</td> <td>10</td> <td>16</td> <td>25</td> <td>35</td> <td>50</td> </tr> <tr> <td>tanδ</td> <td>0.26</td> <td>0.19</td> <td>0.16</td> <td>0.14</td> <td>0.13</td> <td>0.12</td> </tr> </table>	WV	6.3	10	16	25	35	50	tanδ	0.26	0.19	0.16	0.14	0.13	0.12							
	WV	6.3	10	16	25	35	50															
tanδ	0.26	0.19	0.16	0.14	0.13	0.12																
Low temperature characteristics (Impedance ratio at 120Hz)	<table border="1"> <tr> <td>WV</td> <td>6.3</td> <td>10</td> <td>16</td> <td>25</td> <td>35</td> <td>50</td> </tr> <tr> <td>Z-25°C/Z+20°C</td> <td>2</td> <td>2</td> <td>2</td> <td>2</td> <td>2</td> <td>2</td> </tr> <tr> <td>Z-55°C/Z+20°C</td> <td>4</td> <td>4</td> <td>4</td> <td>3</td> <td>3</td> <td>3</td> </tr> </table>	WV	6.3	10	16	25	35	50	Z-25°C/Z+20°C	2	2	2	2	2	2	Z-55°C/Z+20°C	4	4	4	3	3	3
	WV	6.3	10	16	25	35	50															
	Z-25°C/Z+20°C	2	2	2	2	2	2															
Z-55°C/Z+20°C	4	4	4	3	3	3																
Load life (after application of the rated voltage for 5000 hours at 105°C)	Leakage current	Less than specified value																				
	Capacitance change	Within ±30% of initial value																				
	tanδ	Less than 250% of specified value																				
Ø6.3 and 8×6.2 product are for 3000 hours																						
Shelf life (at 105°C)	After 1000 hours no load test, leakage current, capacitance and tanδ are same as load life value. The measurement shall be performed at 20°C by the KS C 6503 clause 5.1.																					
Resistance to soldering heat	The following specifications shall be satisfied when the capacitors are restored to 20°C after exposing them at 250°C for 30 seconds.																					
	Leakage current	Less than specified value																				
	Capacitance change	Within ±10% of initial value																				
	tanδ	Less than specified value																				

## DRAWING

Unit : mm

-Series code of CM is "M"

(Ø6.3×5.8, 7.7, Ø8×6.2)

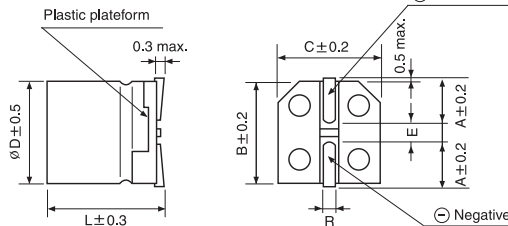
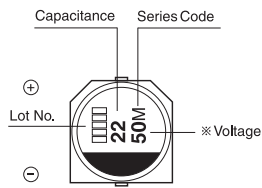

ØD	A	B	C	E	R
6.3×5.8	2.4	6.6	6.6	2.2	0.5~0.8
6.3×7.7	2.4	6.6	6.6	2.2	0.5~0.8
8×6.2	3.3	8.3	8.3	2.3	0.5~0.8
8×10	2.9	8.3	8.3	3.1	0.8~1.1
10×10	3.2	10.3	10.3	4.5	0.8~1.1

(Ø8×10, Ø10×10)

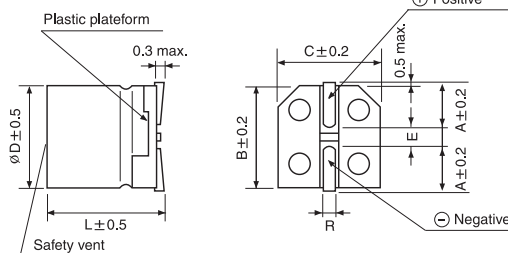
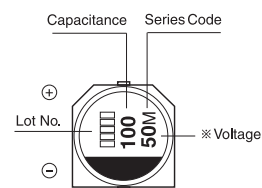

※ Voltage mark for 6.3V is F6<sub>J</sub>

**CM** series

● DIMENSIONS & MAXIMUM PERMISSIBLE RIPPLE CURRENT

$\mu F$ \ WV	6.3			10			16			25			35			50		
10																6.3×5.8	0.86	170
15																6.3×5.8	0.86	170
22																6.3×5.8	0.86	170
33							6.3×5.8	0.39	240	6.3×5.8	0.39	240	6.3×5.8	0.39	240	6.3×7.7	0.66	280
																8×6.2	0.63	300
47				6.3×5.8	0.39	240	6.3×5.8	0.39	240	6.3×5.8	0.39	240	6.3×5.8	0.39	240	6.3×7.7	0.66	280
																8×6.2	0.63	300
68	6.3×5.8	0.36	240	6.3×5.8	0.36	240	6.3×5.8	0.36	240	6.3×5.8	0.36	240	6.3×7.7	0.32	290	8×10	0.32	350
100	6.3×5.8	0.36	240	6.3×5.8	0.36	240	6.3×5.8	0.36	240	6.3×7.7	0.32	290	8×10	0.16	600	10×10	0.16	700
										8×6.2	0.26	300						
150	6.3×5.8	0.36	240	6.3×5.8	0.36	240	6.3×7.7	0.32	290	8×10	0.16	600	8×10	0.16	600			
220	6.3×5.8	0.36	240	6.3×7.7	0.36	290	6.3×7.7	0.32	290	8×10	0.16	600	10×10	0.08	850			
				8×6.2	0.26	300	8×6.2	0.26	300									
330	6.3×7.7	0.32	290	8×10	0.16	600	8×10	0.16	600	10×10	0.08	850						
	8×6.2	0.26	300															
470	8×10	0.16	600	8×10	0.16	600	10×10	0.08	850	← Ripple current (mA rms) at 105°C, 100kHz								
680	8×10	0.16	600	10×10	0.08	850				↑ Impedance (Ω) at 20°C, 100kHz								
1000	10×10	0.08	850							↑ Case size ØD × L (mm)								

CHIP TYPES

● FREQUENCY COEFFICIENT OF PERMISSIBLE RIPPLE CURRENT

Frequency	50Hz	120Hz	300Hz	1kHz	10kHz ≤
Coefficient	0.35	0.5	0.64	0.83	1.00

# SURFACE MOUNT ALUMINUM ELECTROLYTIC CAPACITORS

**CA** Chip type, Long Life, High CV Series

**LL** Long Life      **S** Solvent Proof

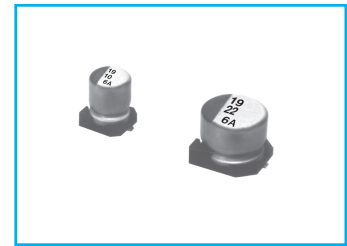

- Chip type, long life capacitance in large case sizes
- Chip type with load life of 5000 hours at +105°C
- Designed for surface mounting on high density PC board
- Applicable to automatic insertion machine using carrier tape
- Complied to the RoHS directive

**JC** → **CA**  
Long life

Item	Characteristics																					
Operating temperature range	-55 ~ +105°C																					
Leakage current max.	$I = 0.01CV$ or $3\mu A$ whichever is greater (after 2 minutes)																					
Capacitance tolerance	$\pm 20\%$ at 120Hz, 20°C																					
Dissipation factor max. (at 120Hz, 20°C)	<table border="1"> <tr> <td>WV</td> <td>6.3</td> <td>10</td> <td>16</td> <td>25</td> <td>35</td> <td>50</td> </tr> <tr> <td>tan<math>\delta</math></td> <td>0.28</td> <td>0.24</td> <td>0.2</td> <td>0.16</td> <td>0.13</td> <td>0.12</td> </tr> </table>	WV	6.3	10	16	25	35	50	tan $\delta$	0.28	0.24	0.2	0.16	0.13	0.12							
	WV	6.3	10	16	25	35	50															
tan $\delta$	0.28	0.24	0.2	0.16	0.13	0.12																
Low temperature characteristics (Impedance ratio at 120Hz)	<table border="1"> <tr> <td>WV</td> <td>6.3</td> <td>10</td> <td>16</td> <td>25</td> <td>35</td> <td>50</td> </tr> <tr> <td>Z-25°C/Z+20°C</td> <td>4</td> <td>3</td> <td>2</td> <td>2</td> <td>2</td> <td>2</td> </tr> <tr> <td>Z-40°C/Z+20°C</td> <td>10</td> <td>7</td> <td>5</td> <td>3</td> <td>3</td> <td>3</td> </tr> </table>	WV	6.3	10	16	25	35	50	Z-25°C/Z+20°C	4	3	2	2	2	2	Z-40°C/Z+20°C	10	7	5	3	3	3
	WV	6.3	10	16	25	35	50															
	Z-25°C/Z+20°C	4	3	2	2	2	2															
Z-40°C/Z+20°C	10	7	5	3	3	3																
Load life (after application of the rated voltage for 5000 hours at 105°C)	Leakage current	Less than specified value																				
	Capacitance change	Within $\pm 30\%$ of initial value																				
	tan $\delta$	Less than 300% of specified value																				
Shelf life (at 105°C)	After 1000 hours no load test, leakage current, capacitance and tan $\delta$ are same as load life value. The measurement shall be performed at 20°C by the KS C 6503 clause 5.1.																					
Resistance to soldering heat	The following specifications shall be satisfied when the capacitors are restored to 20°C after exposing them at 250°C for 30 seconds.																					
	Leakage current	Less than specified value																				
	Capacitance change	Within $\pm 10\%$ of initial value																				
	tan $\delta$	Less than specified value																				

## ● DRAWING

Unit : mm

-Series code of CA is "A"

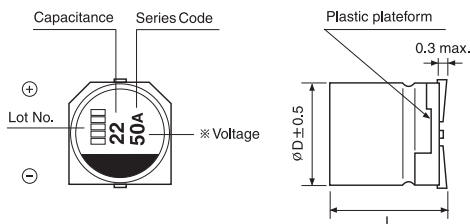

\* Please refer to drawing for CK Series in page 64 for detail drawing.

## ● DIMENSIONS & MAXIMUM PERMISSIBLE RIPPLE CURRENT

$\mu F$	WV	6.3		10		16		25		35		50	
10												6.3×5.8	30
22								6.3×5.8	38	6.3×5.8	42	6.3×7.7	120
33						6.3×5.8	40	6.3×5.8	48	6.3×7.7	57	8×10	140
47				6.3×5.8	46	6.3×5.8	50	6.3×7.7	63	8×10	92	8×10	170
100	6.3×5.8	60	6.3×7.7	81	6.3×7.7	81	8×10	116	10×10	151	10×10	10×10	310
220	6.3×7.7	101	8×10	141	10×10	216	10×10	216	10×10	216			
330	8×10	160	10×10	238	10×10	238	10×10	238					
470	10×10	254	10×10	254	10×10	254							
1000	10×10	313											

← Ripple current (mA rms) at 105°C, 120Hz  
 ↑ Case size  $\phi D \times L$  (mm)

## ● FREQUENCY COEFFICIENT OF PERMISSIBLE RIPPLE CURRENT

Frequency	50Hz	120Hz	300Hz	1kHz	10kHz $\leq$
Coefficient	0.70	1.00	1.17	1.36	1.50

# SURFACE MOUNT ALUMINUM ELECTROLYTIC CAPACITORS



Chip type, High Reliability Series



Long Life



Solvent Proof

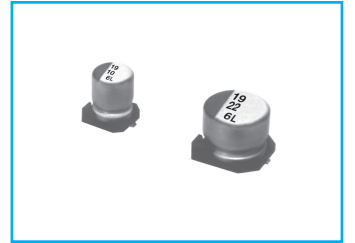

- Chip type, long life capacitance in large case size
- For ECU
- Application to automatic insertion machine using carrier tape
- Complied to the RoHS directive



Item	Characteristics					
Operating temperature range	-40 ~ +105°C					
Leakage current	I = 0.03CV or 4μA whichever is greater (after 2 minutes)					
Capacitance tolerance	±20% (20°C, 120Hz)					
Dissipation factor max. (at 120Hz, 20°C)	Rated Voltage(V)	10	16	25	35	50
	tanδ	0.32	0.24	0.21	0.18	0.18
Low temperature characteristics (Impedance ratio at 120Hz)	WV	10	16	25	35	50
	Z-40°C/Z+20°C	12	10	8	6	6
Load life (after application of the rated voltage for 10000 hours at 105°C)	Leakage current	Less than specified value				
	Capacitance change	Within ±30% of the initial value				
	tanδ	Less than 300% of the specified value				
Shelf life (at 105°C)	After 1000 hours no load test, leakage current, capacitance and tanδ are same as load life value. The measurement shall be performed at 20°C by the KS C 6503 clause 5.1.					
Resistance to soldering heat	The following specifications shall be satisfied when the capacitors are restored to 20°C after exposing them at 250°C for 30 seconds.					
	Leakage current	Less than specified value				
	Capacitance change	Within ±30% of the initial value				
	tanδ	Less than 300% of the specified value				

## ● DRAWING

Unit : mm

-Series code of JL is "L"

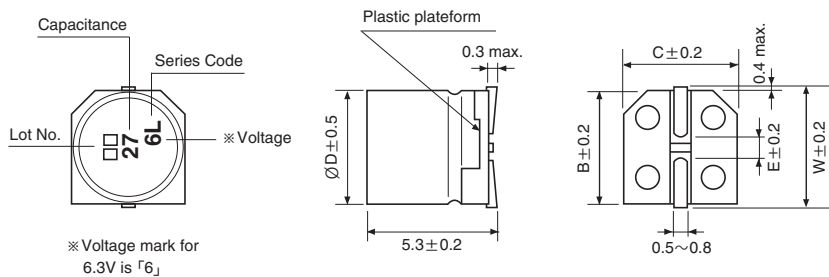

ØD	A	B	C	E	R
8×10	2.9	8.3	8.3	3.1	0.8~1.1
10×10	3.2	10.3	10.3	4.5	0.8~1.1

## ● DIMENSIONS & MAXIMUM PERMISSIBLE RIPPLE CURRENT

μF	10		16		25		35		50	
33									8×10	75
47									8×10	90
100			8×10	270	8×10	163	10×10	132	10×10	167
220	8×10	270	8×10	270	10×10	200	10×10	249		
330	8×10	270	10×10	315	10×10	304				
470	10×10	315	10×10	315						

Ripple current (mA rms) at 105°C, 120kHz  
Case size ØD×L(mm)

## ● FREQUENCY COEFFICIENT OF PERMISSIBLE RIPPLE CURRENT

Frequency	50Hz	120Hz	300Hz	1kHz	10kHz ≤
Coefficient	0.70	1.00	1.17	1.36	1.50

# SURFACE MOUNT ALUMINUM ELECTROLYTIC CAPACITORS

**CF** Chip type, High Temperature, Long Life, Series

**LL** Long Life  
**S** Solvent Proof



- Chip type, high temperature range, for + 130°C use
- For ECU
- Application to automatic insertion machine using carrier
- Complied to the RoHS directive

**JC** → **CF**  
Wide temp  
Long life

Item	Characteristics					
Operating temperature range	-40 ~ +130°C					
Leakage current	I = 0.03CV or 4 $\mu$ A whichever is greater (after 2 minutes)					
Capacitance tolerance	$\pm 20\%$ (20°C, 120Hz)					
Dissipation factor max. (at 120Hz, 20°C)	Rated Voltage(V)	10	16	25	35	50
	tan $\delta$	0.32	0.24	0.21	0.18	0.18
Low temperature characteristics (Impedance ratio at 120Hz)	WV	10	16	25	35	50
	Z-40°C/Z+20°C	12	11	8	6	6
Load life (after application of the rated voltage for 5000 hours at 130°C)	Leakage current	Less than specified value				
	Capacitance change	Within $\pm 30\%$ of initial value				
	tan $\delta$	Less than 300% of the specified value				
$\varnothing 8 \times 6.2$ : 2000 hours, $\varnothing 8 \times 10$ : 3000 hours, $\varnothing 10 \sim$ : 5000 hours						
Shelf life (at 130°C)	After 1000 hours no load test, leakage current, capacitance and tan $\delta$ are same as load life value. The measurement shall be performed at 20°C by the KS C 6503 clause 5.1.					
Resistance to soldering heat	The following specifications shall be satisfied when the capacitors are restored to 20°C after exposing them at 250°C for 30 seconds.					
	Leakage current	Less than specified value				
	Capacitance change	Within $\pm 10\%$ of initial value				
tan $\delta$ Less than specified value						

● DRAWING (See page 53)

Unit : mm

-Series code of CF is "H"

● DIMENSIONS & MAXIMUM PERMISSIBLE RIPPLE CURRENT

$\mu$ F	WV	10		16		25		35		50	
22										8×6.2	28
33								8×6.2	41	8×10	75
47								10×10	90	10×10	90
68				8×6.2	50	8×6.2	45	10×10	105	12.5×13.5	132
100	8×6.2	48	8×10	66	10×10	163	10×10	132	12.5×13.5	167	
220	8×10	90	10×10	163	10×10	200	12.5×13.5	249			
330	10×10	125	10×10	200	12.5×13.5	304					
470	10×10	150	12.5×13.5	304							
1000	12.5×13.5	405									

↑ Ripple current (mA rms) at 130°C, 120Hz  
 — Case size  $\varnothing D \times L$ (mm)

● FREQUENCY COEFFICIENT OF PERMISSIBLE RIPPLE CURRENT

Frequency	50Hz	120Hz	300Hz	1kHz	10kHz $\leq$
Coefficient	0.70	1.00	1.17	1.36	1.50



## CT Chip type, High Temperature, Low Imp., Series

**IZI** Low Impedance **S** Solvent Proof

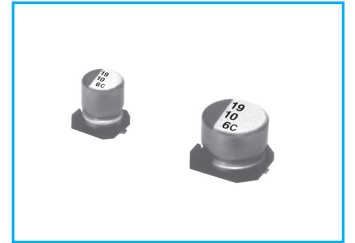

- Chip type, Low Impedance temperature range up to 130°C use
- For ECU
- Application to automatic insertion machine using carrier tape
- Complied to the RoHS directive

CF → **CT**  
Low Imp.

Item	Characteristics					
Operating temperature range	-40 ~ +130°C					
Leakage current max.	I = 0.03CV or 4μA whichever is greater (after 2 minutes)					
Capacitance tolerance	±20% ( 20°C, 120Hz)					
Dissipation factor max. (at 120Hz, 20°C)	Rated Voltage(V)	10	16	25	35	50
	tanδ	0.32	0.24	0.21	0.18	0.18
Low temperature characteristics (Impedance ratio at 120Hz)	WV	10	16	25	35	50
	Z-40°C/Z+20°C	12	10	8	6	6
Load life (after application of the rated voltage for 2000 hours at 130°C)	Leakage Current	Less than specified value				
	Capacitance Change	Within ±30% of initial value				
	tanδ	Less than 300% of specified value				
Shelf life (at 130°C)	After 1000 hours no load test, leakage current, capacitance and tanδ are same as load life value. The measurement shall be performed at 20°C by the KS C 6503 clause 5.1.					
Resistance to soldering heat	The following specifications shall be satisfied when the capacitors are restored to 20°C after exposing them at 250°C for 30 seconds.					
	Leakage Current	Less than specified value				
	Capacitance Change	Within ±10% of initial value				
	tanδ	Less than specified value				

● DRAWING (See page 53)

Unit : mm

-Series code of CT is "C"

● DIMENSIONS & MAXIMUM PERMISSIBLE RIPPLE CURRENT

μF	WV	10			16			25			35			50		
		33														
47											8×10	0.6	270	8×10	0.6	270
68					8×10	0.6	270	8×10	0.6	270	10×10	0.5	270	10×10	0.5	315
100	8×10	0.6	270	8×10	0.6	270	8×10	0.6	270	10×10	0.5	315	12.5×13.5	0.4	345	
220	8×10	0.6	270	8×10	0.6	270	10×10	0.5	315	12.5×13.5	0.4	345				
330	10×10	0.5	315	10×10	0.5	315	12.5×13.5	0.4	345							
470	10×10	0.5	315	12.5×13.5	0.4	345										

← Ripple current (mA rms) at 130°C, 100kHz  
 ↑ Impedance (Ω) at 20°C, 100kHz  
 ↑ Case size ØD×L(mm)

● FREQUENCY COEFFICIENT OF PERMISSIBLE RIPPLE CURRENT

Frequency	50Hz	120Hz	300Hz	1kHz	10kHz ≤
Coefficient	0.35	0.5	0.64	0.83	1.00

# SURFACE MOUNT ALUMINUM ELECTROLYTIC CAPACITORS

**CW** Chip type, High Reliability Series

- Chip type, high temperature range, for + 150°C use
- Applicable to automatic insertion machine using carrier tape
- Complied to the RoHS directive

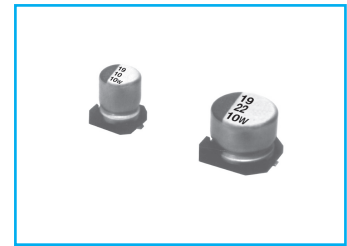
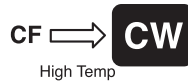

Item	Characteristics					
Operating temperature range	-40 ~ +150°C					
Leakage current	I = 0.03CV or 4μA whichever is greater (after 2 minutes)					
Capacitance tolerance	±20% at 120Hz, 20°C					
Dissipation factor max. (at 120Hz, 20°C)	WV	10	16	25	35	50
	tanδ	0.30	0.20	0.16	0.14	0.14
Low temperature characteristics (Impedance ratio at 120Hz)	WV	10	16	25	35	50
	Z-40°C/Z+20°C	12	10	8	6	6
Load life (after application of the rated voltage for 1000 hours at 150°C)	Leakage current	Less than specified value				
	Capacitance change	Within ±30% of initial value				
	tanδ	Less than 300% of the specified value				
Shelf life (at 150°C)	After 1000 hours no load test, leakage current, capacitance and tanδ are same as load life value. The measurement shall be performed at 20°C by the KS C 6503 clause 5.1.					
Resistance to soldering heat	The following specifications shall be satisfied when the capacitors are restored to 20°C after exposing them at 250°C for 30 seconds.					
	Leakage current	Less than specified value				
	Capacitance change	Within ±10% of initial value				
	tanδ	Less than specified value				

● DRAWING (See page 53)

Unit : mm

-Series code of CW is "W"

● DIMENSIONS & MAXIMUM PERMISSIBLE RIPPLE CURRENT

μF \ WV	10		16		25		35		50	
33									10×10	75
47							10×10	90	10×10	90
68							10×10	105	12.5×13.5	132
100					10×10	160	10×10	132	12.5×13.5	167
220			10×10	163	10×10	200	12.5×13.5	249		
330	10×10	183	10×10	200	12.5×13.5	304				
470	10×10	218	12.5×13.5	304						
1000	12.5×13.5	405								

Ripple current (mA rms) at 150°C, 120Hz  
Case size ØD×L(mm)

● FREQUENCY COEFFICIENT OF PERMISSIBLE RIPPLE CURRENT

Frequency	50Hz	120Hz	300Hz	1kHz	10kHz ≤
Coefficient	0.70	1.00	1.17	1.36	1.50

## NC Chip type, Non-polarized Series

**NP** Non-polarized  
**S** Solvent Proof

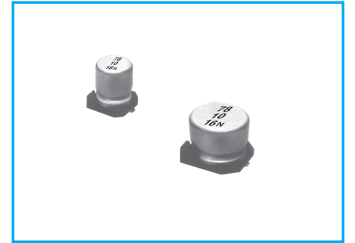

- Chip type with 5.5mmL height
- Designed for surface mounting on high density PC board
- Applicable to automatic mounting machine using carrier tape
- Complied to the RoHS directive



Item	Characteristics						
Operating temperature range	-40 ~ +85°C						
Leakage current max.	I = 0.05CV or 10μA whichever is greater (after 2 minutes)						
Capacitance tolerance	±20% at 120Hz, 20°C						
Dissipation factor max. (at 120Hz, 20°C)	WV	6.3	10	16	25	35	50
	tanδ	0.24	0.20	0.17	0.17	0.15	0.15
Low temperature characteristics (Impedance ratio at 120Hz)	WV	6.3	10	16	25	35	50
	Z-25°C/Z+20°C	4	3	2	2	2	2
	Z-40°C/Z+20°C	8	6	4	4	3	3
Load life (after application of the rated voltage for 2000 hours at 85°C)	Leakage current	Less than specified value					
	Capacitance change	Within ±20% of initial value					
	tanδ	Less than 200% of specified value					
	Test method	Polarity reverse each 250 hours					
Shelf life (at 85°C)	After 1000 hours no load test, leakage current, capacitance and tanδ are same as load life value. The measurement shall be performed at 20°C by the KS C 6503 clause 5.1.						
Resistance to soldering heat	The following specifications shall be satisfied when the capacitors are restored to 20°C after exposing them at 250°C for 30 seconds.						
	Leakage current	Less than specified value					
	Capacitance change	Within ±10% of initial value					
	tanδ	Less than specified value					

### ● DRAWING

Unit : mm

-Series code of NC is "N"

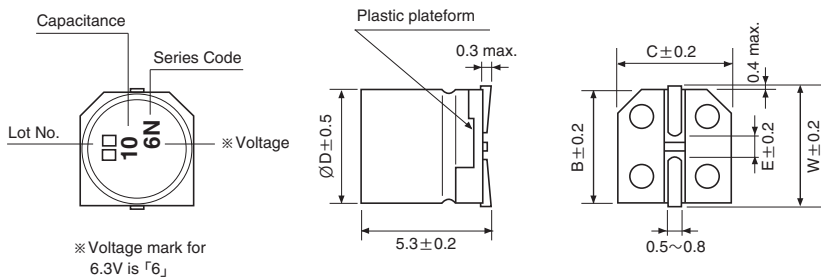

ØD	W	B	C	E
4	4.8	4.3	4.3	1.0
5	5.8	5.3	5.3	1.4
6.3	7.1	6.6	6.6	2.2

### ● DIMENSIONS & MAXIMUM PERMISSIBLE RIPPLE CURRENT

μF \ WV	6.3	10	16	25	35	50
0.1						4×5.3 1.0
0.22						4×5.3 2.0
0.33						4×5.3 2.8
0.47						4×5.3 4.0
1.0						4×5.3 8.4
2.2					4×5.3 8.4	5×5.3 13
3.3				5×5.3 12	5×5.3 16	5×5.3 17
4.7			4×5.3 12	5×5.3 16	5×5.3 18	6.3×5.3 20
10		4×5.3 17	5×5.3 23	6.3×5.3 27	6.3×5.3 29	
22	5×5.3 28	6.3×5.3 33	6.3×5.3 37			
33	6.3×5.3 37	6.3×5.3 41	6.3×5.3 49			
47	6.3×5.3 45					

Ripple current (mA rms) at 85°C, 120Hz  
Case size ØD x L (mm)

# SURFACE MOUNT ALUMINUM ELECTROLYTIC CAPACITORS

**CN** Height 5.5mmL, 105°C Non-polarized Series

**NP** Non-polarized **S** Solvent Proof

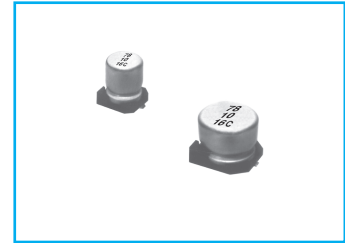

- Chip type, Non-polarized, Wide temperature 105°C
- Chip type with 5.5mmL height
- Designed for surface mounting on high density PC board
- Applicable to automatic insertion machine using carrier tape
- Complied to the RoHS directive

NC → CN  
Wide temp.

Item	Characteristics																					
Operating temperature range	-55 ~ +105°C																					
Leakage current max.	$I = 0.05CV$ or $10\mu A$ whichever is greater (after 2 minutes)																					
Capacitance tolerance	$\pm 20\%$ at 120Hz, 20°C																					
Dissipation factor max. (at 120Hz, 20°C)	<table border="1"> <tr> <td>WV</td> <td>6.3</td> <td>10</td> <td>16</td> <td>25</td> <td>35</td> <td>50</td> </tr> <tr> <td>tan<math>\delta</math></td> <td>0.32</td> <td>0.26</td> <td>0.24</td> <td>0.20</td> <td>0.18</td> <td>0.18</td> </tr> </table>	WV	6.3	10	16	25	35	50	tan $\delta$	0.32	0.26	0.24	0.20	0.18	0.18							
	WV	6.3	10	16	25	35	50															
tan $\delta$	0.32	0.26	0.24	0.20	0.18	0.18																
Low temperature characteristics (Impedance ratio at 120Hz)	<table border="1"> <tr> <td>WV</td> <td>6.3</td> <td>10</td> <td>16</td> <td>25</td> <td>35</td> <td>50</td> </tr> <tr> <td>Z-25°C/Z+20°C</td> <td>4</td> <td>3</td> <td>2</td> <td>2</td> <td>2</td> <td>2</td> </tr> <tr> <td>Z-40°C/Z+20°C</td> <td>8</td> <td>6</td> <td>4</td> <td>4</td> <td>3</td> <td>3</td> </tr> </table>	WV	6.3	10	16	25	35	50	Z-25°C/Z+20°C	4	3	2	2	2	2	Z-40°C/Z+20°C	8	6	4	4	3	3
	WV	6.3	10	16	25	35	50															
	Z-25°C/Z+20°C	4	3	2	2	2	2															
Z-40°C/Z+20°C	8	6	4	4	3	3																
Load life (after application of the rated voltage for 1000 hours at 105°C)	Leakage current	Less than specified value																				
	Capacitance change	Within $\pm 20\%$ of initial value																				
	tan $\delta$	Less than 200% of specified value																				
	Test method	Polarity reverse each 250 hours																				
Shelf life (at 105°C)	After 1000 hours no load test, leakage current, capacitance and tan $\delta$ are same as load life value. The measurement shall be performed at 20°C by the KS C 6503 clause 5.1.																					
Resistance to soldering heat	The following specifications shall be satisfied when the capacitors are restored to 20°C after exposing them at 250°C for 30 seconds.																					
	Leakage current	Less than specified value																				
	Capacitance change	Within $\pm 10\%$ of initial value																				
	tan $\delta$	Less than specified value																				

## ● DRAWING

Unit : mm

-Series code of CN is "C"

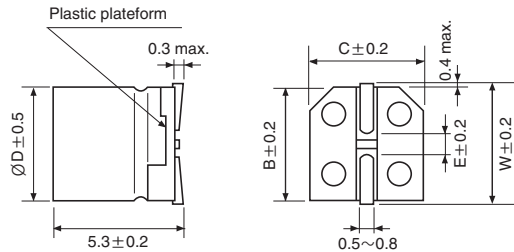
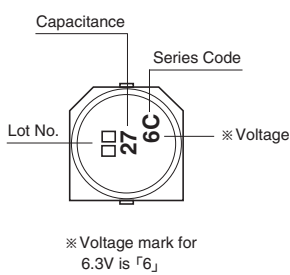

ØD	W	B	C	E
4	4.8	4.3	4.3	1.0
5	5.8	5.3	5.3	1.4
6.3	7.1	6.6	6.6	2.2

## ● DIMENSIONS & MAXIMUM PERMISSIBLE RIPPLE CURRENT

µF \ WV	6.3	10	16	25	35	50
0.1						4×5.3 1.3
0.22						4×5.3 2.3
0.33						4×5.3 2.8
0.47						4×5.3 4.0
1.0						4×5.3 8.4
2.2					4×5.3 8.4	5×5.3 13
3.3				5×5.3 12	5×5.3 16	5×5.3 17
4.7			4×5.3 12	5×5.3 16	5×5.3 18	6.3×5.3 20
10		4×5.3 17	5×5.3 23	6.3×5.3 27	6.3×5.3 29	
22	5×5.3 28	6.3×5.3 33	6.3×5.3 37			
33	6.3×5.3 37	6.3×5.3 41	6.3×5.3 49			
47	6.3×5.3 45					

↑ ↑  
Ripple current (mA rms) at 105°C, 120Hz  
Case size ØD×L (mm)