



MESSRS. SIRICOM

SPECIFICATION FOR APPROVAL

承 認 承 書

Product	ELECTRO MAGNETIC BUZZER
Part No.	AC-12T5A
Customer Approval	
Customer Part No.	

Approved By	Checked By	Made By
		



Advanced Acoustic Technology Corporation
昊宸股份有限公司 // 常州笠翔电子有限公司



ISO 9001 Certified

ISO 14001 Certified

Head Office / 2F, No.207, Sec. 6, Chung Shan N. Rd., Taipei, Taiwan

Tel: +886-2-8866-5255

Fax: +886-2-8866-5250

RoHS

1. SPECIFICATION

AC-12T5A

ITEM		UNITS	SPECIFICATIONS	CONDITIONS
01	Rated Voltage	V	5.0	 Standard state, standard drive circuit. Square wave 1/2 duty.
02	Operating Voltage	V	3.0 ~ 8.0	
03	Consumption Current	mA Max.	100	
04	Sound pressure level (Distance at 10cm)	dB(A) Min.	85	Rated voltage, rated frequency.
05	Direct Current Resistance	Ω	16 \pm 4	
06	Rated Frequency	Hz	2048	
07	Operating Temp.	$^{\circ}\text{C}$	-30 ~ +70	
08	Storage Temp.	$^{\circ}\text{C}$	-40 ~ +85	
09	Weight	g	2	

2. MEASURING METHOD

2-1. Test Condition

STANDARD

Temperature : 15 ~ 35 $^{\circ}\text{C}$

Relative humidity : 45% ~ 85%,

Atmospheric pressure: 860mbar to 1060mbar.

JUDGEMENT

Temperature : 20 \pm 3 $^{\circ}\text{C}$

Relative humidity : 60% ~ 70%,

Atmospheric pressure : 860mbar to 1060mbar

2-2. Standard drive circuit

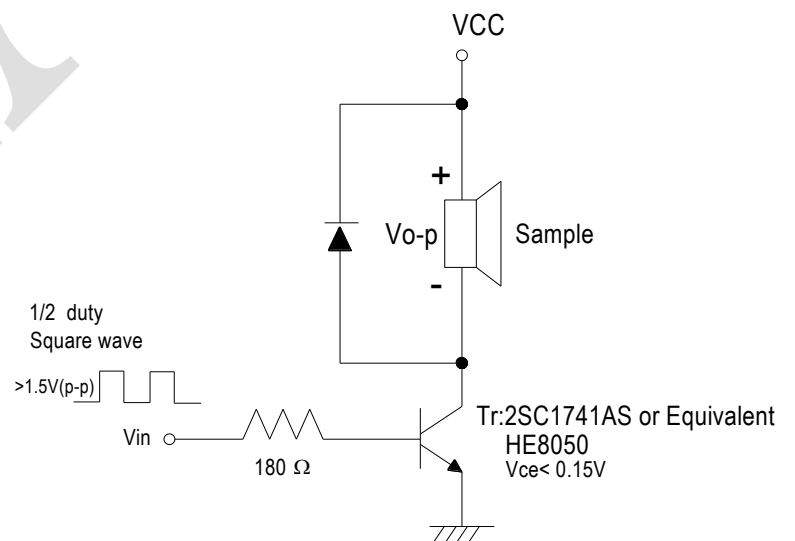

2-3. Standard Test Fixture

Distance: $X=10\text{ cm}$

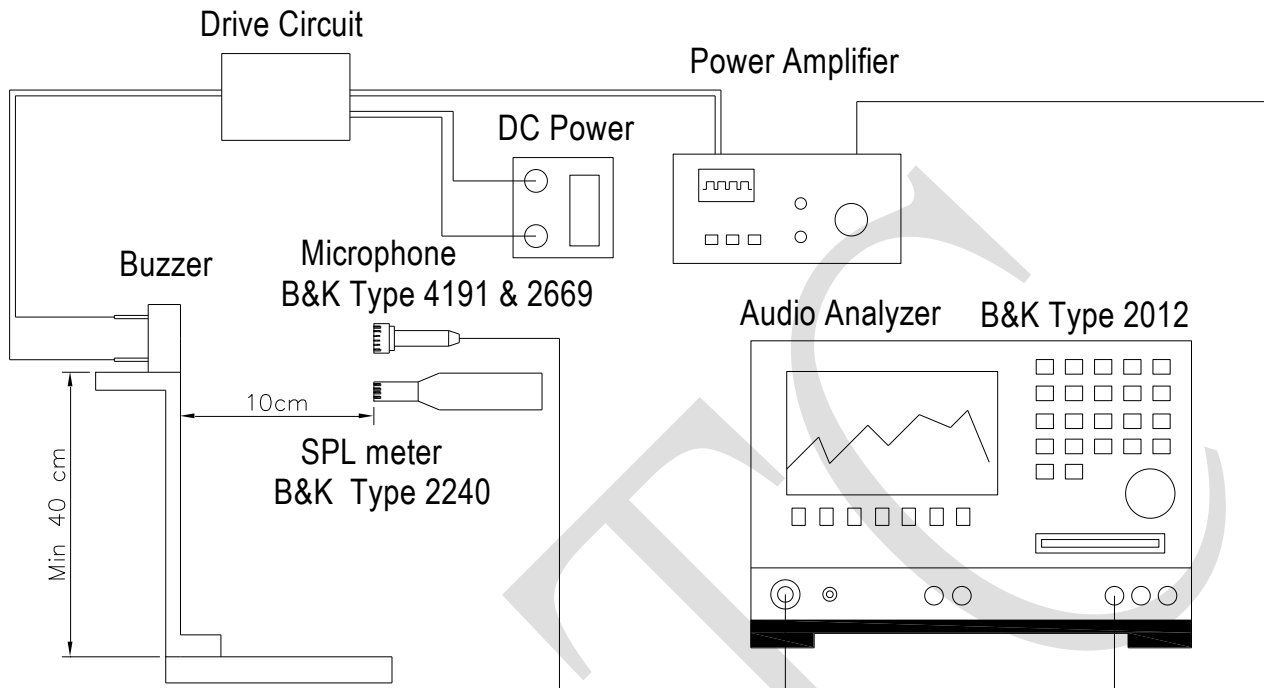

2-4. Frequency Response Curve

X:2.0535kHz Y:93.26dB ZA:Live Curve SSR T. RMS

A: Frequency Response, Magn dB re 20.00 μ PA

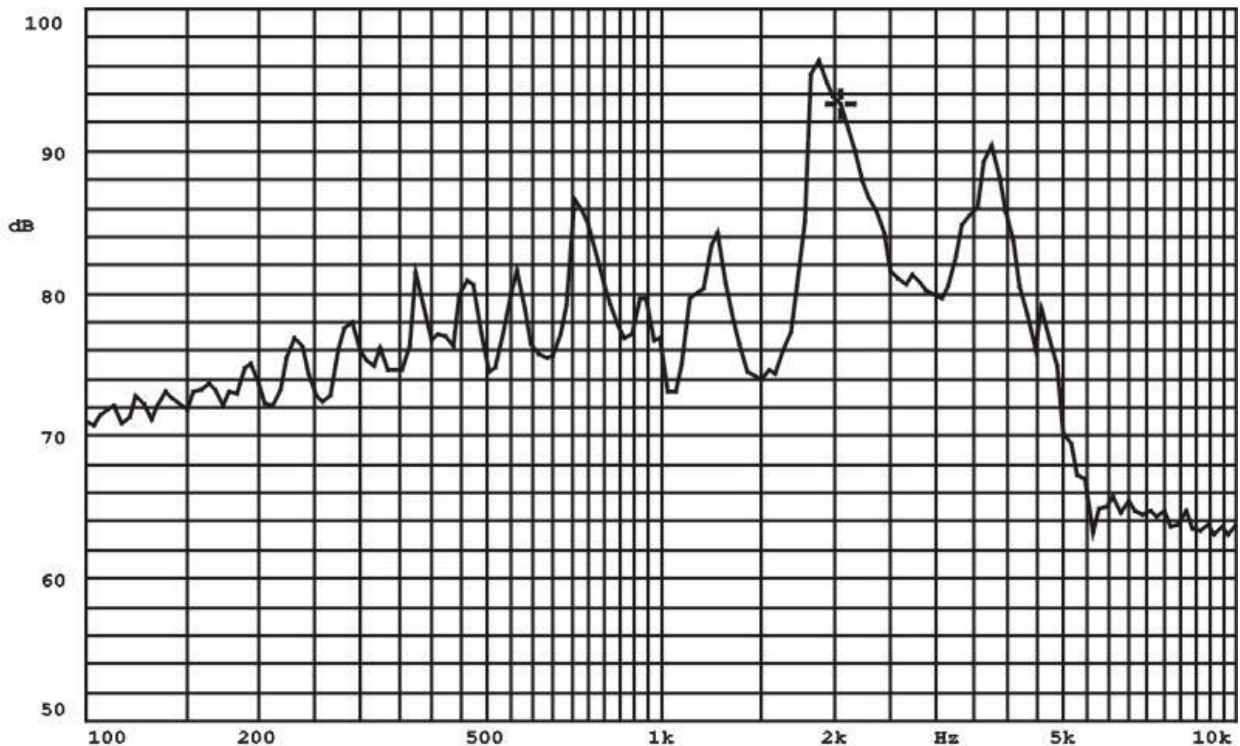

05-AUG-2009 13:08:52

Mode: SSR



3.DIMENSIONS

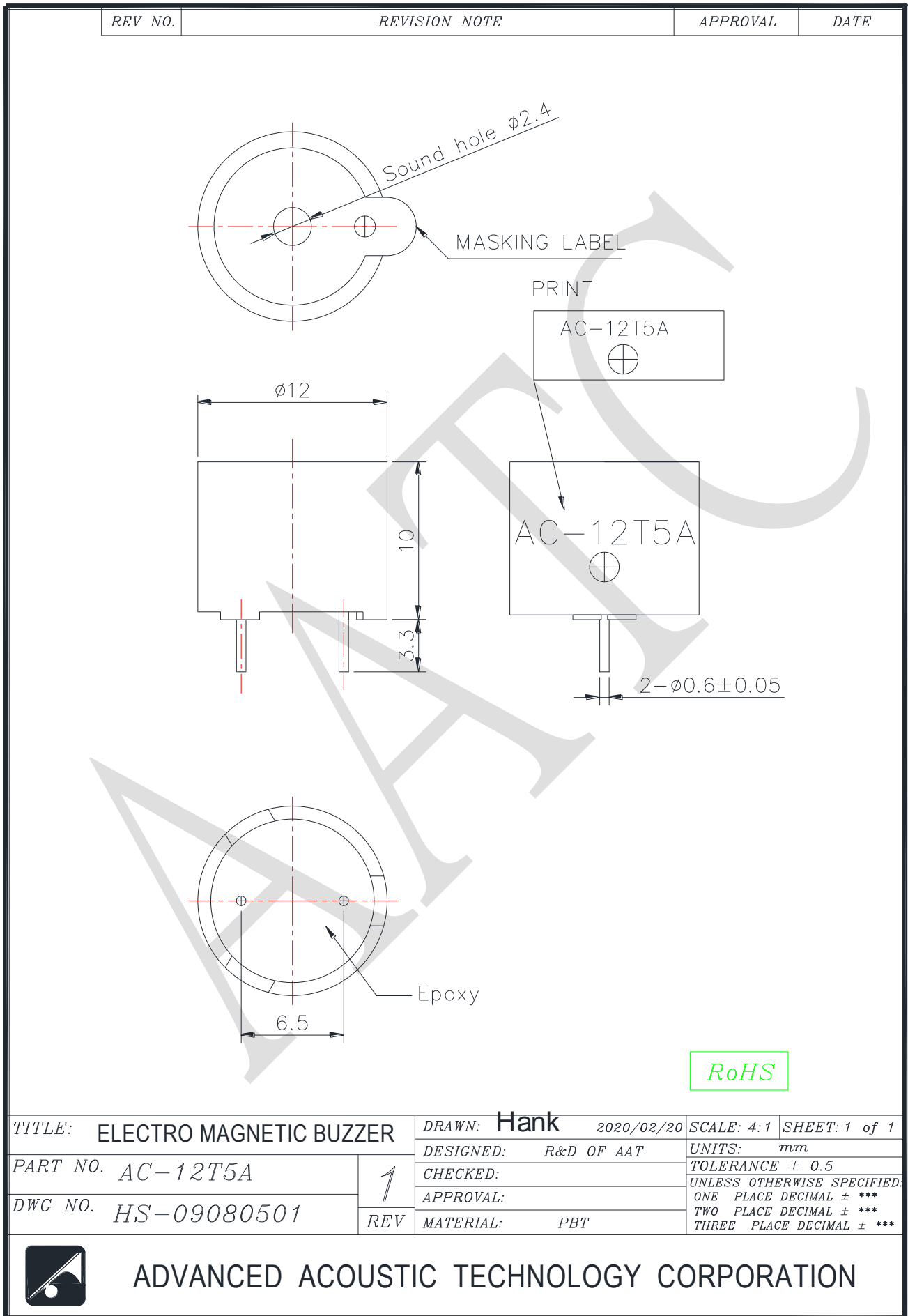

TITLE: ELECTRO MAGNETIC BUZZER		DRAWN: Hank	2020/02/20	SCALE: 4:1	SHEET: 1 of 1
PART NO. AC-12T5A		DESIGNED: R&D OF AAT		UNITS: mm	TOLERANCE ± 0.5
DWG NO. HS-09080501		CHECKED:		UNLESS OTHERWISE SPECIFIED:	
		APPROVAL:		ONE PLACE DECIMAL \pm ***	
REV	1	MATERIAL: PBT		TWO PLACE DECIMAL \pm ***	
				THREE PLACE DECIMAL \pm ***	



ADVANCED ACOUSTIC TECHNOLOGY CORPORATION

4. RELIABILITY TESTS

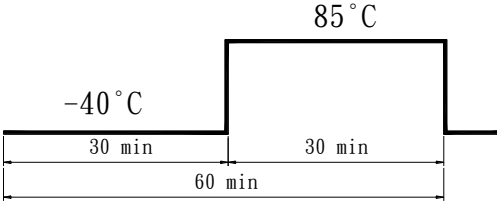
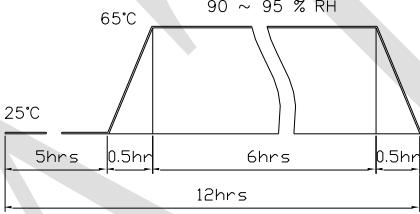
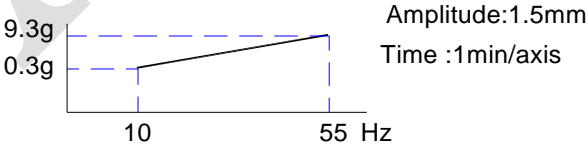
Item	Test conditions	Evaluation standard
01 High temp. Storage life	The part shall be capable of withstanding a storage Temperature of +85°C for 96 hours.	<p>1. After the test the part shall meet specifications without Any degradation in appearance and performance except S.P.L</p> <p>2. S.P.L shall be ± 7 dB.</p>
02 Low temp. Storage life	The part shall be capable of withstanding a storage Temperature of -40°C for 96 hours.	
03 Temp. cycle	<p>The part shall be subjected 10 cycles. One cycle shall of ;</p> 	
04 Temp./Humidity cycle	<p>The part shall be subjected 10 cycles. One cycle shall of;</p> 	
05 Operating life	<p>Rated Voltage, Frequency applied.</p> <ol style="list-style-type: none"> Ordinary temperature The part shall be subjected to 1000 hours at room temperature ($25 \pm 10^\circ\text{C}$) High temperature The part shall be subjected to 500 hours at 70°C Low temperature The part shall be subjected to 500 hours at -30°C 	
06 Vibration	 <p>Make this test for the directions of X, Y, Z for 2 hours each (total 6 hours).</p>	
07 Lead strength	Pull lead with a force of 9.8N, on the direction of the lead axis for 10 : 10 ± 1 sec	

Item	Test conditions	Evaluation standard
08	Free drop The part only shall be dropped from a height of 75cm onto a 40mm thick wooden board 1 times in 3 Direction each (X.Y.Z). (a total of 3 times).	1. After the test the part shall meet specifications without Any degradation in appearance and performance except S.P.L 2. S.P.L shall be ± 7 dB.
	Free drop (Packing) The part only shall be dropped from a height of 100cm onto a 10mm thick wooden board 1 times in 3 axes (X.Y.Z). (a total of 3 times).	

5. CAUTIONS FOR USE

01	As this product is not protected from foreign material entering, please make sure that any foreign materials do not enter this product in your production processes. (e.g. magnetic powder, washing solvent, flux, corrosive gas) 由於本產品不能防止異物進入，請確保任何異物不會在生產過程中進入本產品。 (例如磁粉，洗滌溶劑，焊劑，腐蝕性氣體)
02	The functional degradation may occur if foreign material enter it. (e.g. SPL down) 如果外來物質進入，則可能發生功能退化。(例如 SPL 下降)
03	Wash ability 耐洗性 Solvent : deionizer water 溶劑：去離子水 Solvent temp : $55\pm 5^{\circ}\text{C}$ 溶劑溫度： $55\pm 5^{\circ}\text{C}$ Soaking time : 5 ± 0.5 min. 浸泡時間： 5 ± 0.5 分鐘 After the washing process, be sure to tear off the label. 在洗滌過程後，一定要撕下標籤。
04	After solder bath, the cooling time must be longer than 2 hours before function test. 測試功能前，必須在過完錫爐後並冷卻 2 小時以上。
05	Soldering profile 爐溫曲線 Soldering into solder bath: $250\pm 5^{\circ}\text{C}$, 5 ± 1 Sec. 錫爐溫度: $250\pm 5^{\circ}\text{C}$, 5 ± 1 Sec.

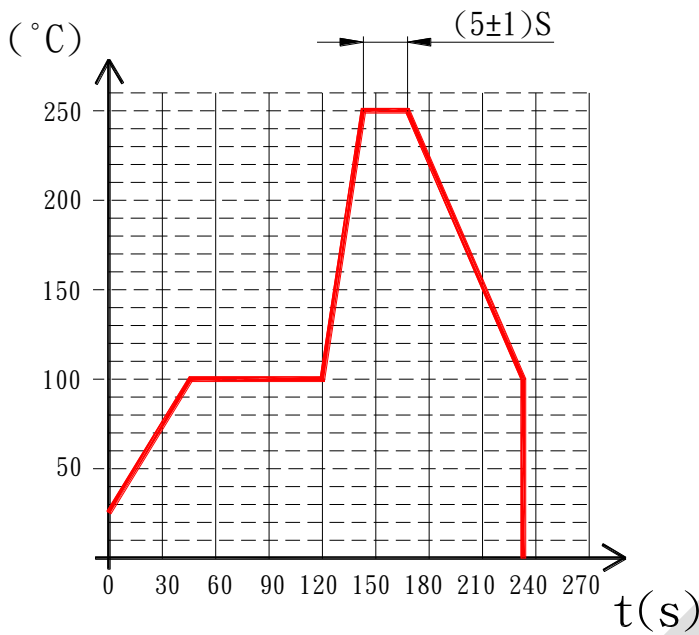

06	<p>Soldering with iron 焊接 Hand soldering : $360\pm 10^{\circ}\text{C} / \leq 2 \text{ Sec.}$ 手焊: $360\pm 10^{\circ}\text{C} / \leq 2 \text{ Sec.}$ Recommend using constant searing-iron 建議使用烙鐵</p>
07	<p>AATC reserves the right to change product material without prior notice, guaranteeing the same specification. Materials are subject to change due to environmental regulations, sourcing, and process improvements. 材料可能由於環境法規，物料及製程工藝精進而發生變動，AATC 保證相同的規格，並有權保留更改產品材料的權利，恕不另行通知。</p>
08	<p>If you need more information, please contact our technology department, thank you 如您需要更多信息，請聯繫我們的技術部門，謝謝。</p>

6. PACKING

